

09-29-00

A



jc917 U.S. PTO  
09/28/00

DOCKET NO. : MSFT-0179/150657.1

PATENT

IN THE UNITED STATES PATENT AND TRADEMARK OFFICE



jc929 U.S. PTO  
09/28/00  
09/28/00

In Re Application of:

Rajasekhar Abburi

Serial No.: Not Yet Assigned

Group Art Unit: Not Yet Assigned

Filing Date: Herewith

Examiner: Not Yet Assigned

For: RETAIL TRANSACTIONS INVOLVING DISTRIBUTED AND SUBER-DISTRIBUTED DIGITAL CONTENT IN A DIGITAL RIGHTS MANAGEMENT (DRM) SYSTEM

EXPRESS MAIL LABEL NO: EL531429456US  
DATE OF DEPOSIT: September 28, 2000

- Box  Patent Application
- Provisional  Design

Assistant Commissioner for Patents  
Washington DC 20231

Sir:

PATENT APPLICATION TRANSMITTAL LETTER

Transmitted herewith for filing, please find

- A Utility Patent Application under 37 C.F.R. 1.53(b).

It is a continuing application, as follows:

- continuation  divisional  continuation-in-part of prior application number \_\_\_\_\_

- A Provisional Patent Application under 37 C.F.R. 1.53(c).
- A Design Patent Application (submitted in duplicate).

09/28/00 09/28/00

Including the following:

- Provisional Application Cover Sheet.
- New or Revised Specification, including pages 1 to 98 containing:
  - Specification
  - Claims
  - Abstract
  - Substitute Specification, including Claims and Abstract.
    - The present application is a continuation application of Application No. \_\_\_\_\_ filed \_\_\_\_\_. The present application includes the Specification of the parent application which has been revised in accordance with the amendments filed in the parent application. Since none of those amendments incorporate new matter into the parent application, the present revised Specification also does not include new matter.
    - The present application is a continuation application of Application No. \_\_\_\_\_ filed \_\_\_\_\_, which in turn is a continuation-in-part of Application No. \_\_\_\_\_ filed \_\_\_\_\_. The present application includes the Specification of the parent application which has been revised in accordance with the amendments filed in the parent application. Although the amendments in the parent C-I-P application may have incorporated new matter, since those are the only revisions included in the present application, the present application includes no new matter in relation to the parent application.
- A copy of earlier application Serial No. \_\_\_\_\_ Filed \_\_\_\_\_, including Specification, Claims and Abstract (pages 1 - @@), to which no new matter has been added TOGETHER WITH a copy of the executed oath or declaration for such earlier application and all drawings and appendices. Such earlier application is hereby incorporated into the present application by reference.
- Please enter the following amendment to the Specification under the Cross-Reference to Related Applications section (or create such a section) : "This Application:
  - is a continuation of  is a divisional of  claims benefit of U.S. provisional Application Serial No. \_\_\_\_\_ filed \_\_\_\_\_

0000000000000000

\_\_\_\_\_  
\_\_\_\_\_  
\_\_\_\_\_

- Signed Statement attached deleting inventor(s) named in the prior application.
- A Preliminary Amendment.
- Sixteen Sheets of  Formal  Informal Drawings.
- Petition to Accept Photographic Drawings.
- Petition Fee
- An  Executed  Unexecuted Declaration or Oath and Power of Attorney.
- An Associate Power of Attorney.
- An  Executed  Copy of Executed Assignment of the Invention to \_\_\_\_\_  
\_\_\_\_\_
  - A Recordation Form Cover Sheet.
  - Recordation Fee - \$40.00.
- The prior application is assigned of record to \_\_\_\_\_
- Priority is claimed under 35 U.S.C. § 119 of Patent Application No. \_\_\_\_\_  
filed \_\_\_\_\_ in \_\_\_\_\_ (country).
  - A Certified Copy of each of the above applications for which priority is claimed:
    - is enclosed.
    - has been filed in prior application Serial No. \_\_\_\_\_ filed \_\_\_\_\_ .
- An  Executed or  Copy of Executed Earlier Statement Claiming Small Entity Status under 37 C.F.R. 1.9 and 1.27
  - is enclosed.
  - has been filed in prior application Serial No. \_\_\_\_\_ filed \_\_\_\_\_ ,  
said status is still proper and desired in present case.

COPIES OF THE ORIGINAL

- Diskette Containing DNA/Amino Acid Sequence Information.
- Statement to Support Submission of DNA/Amino Acid Sequence Information.
- The computer readable form in this application \_\_\_\_\_, is identical with that filed in Application Serial Number \_\_\_\_\_, filed \_\_\_\_\_. In accordance with 37 CFR 1.821(e), please use the  first-filed,  last-filed or  only computer readable form filed in that application as the computer readable form for the instant application. It is understood that the Patent and Trademark Office will make the necessary change in application number and filing date for the computer readable form that will be used for the instant application. A paper copy of the Sequence Listing is  included in the originally-filed specification of the instant application,  included in a separately filed preliminary amendment for incorporation into the specification.
- Information Disclosure Statement.
  - Attached Form 1449.
  - Copies of each of the references listed on the attached Form PTO-1449 are enclosed herewith.
- A copy of Petition for Extension of Time as filed in the prior case.
- Appended Material as follows: \_\_\_\_\_
- Return Receipt Postcard (should be specifically itemized).
- Other as follows: \_\_\_\_\_  
 \_\_\_\_\_  
 \_\_\_\_\_

000000000000000000000000000000000000

**FEE CALCULATION:**

- Cancel in this application original claims \_\_\_\_\_ of the prior application before calculating the filing fee. (At least one original independent claim must be retained for filing purposes.)

			SMALL ENTITY		NOT SMALL ENTITY	
			RATE	FEE	RATE	FEE
PROVISIONAL APPLICATION			\$75.00	\$	\$150.00	\$0
DESIGN APPLICATION			\$155.00	\$	\$310.00	\$0
UTILITY APPLICATIONS BASE FEE			\$345.00	\$	\$690.00	\$690.00
UTILITY APPLICATION; ALL CLAIMS CALCULATED AFTER ENTRY OF ALL AMENDMENTS						
	No. Filed	No. Extra				
TOTAL CLAIMS	81 - 20 =	61	\$9 each	\$	\$18 each	\$1098.00
INDEP. CLAIMS	8 - 3 =	5	\$39 each	\$	\$78 each	\$390.00
FIRST PRESENTATION OF MULTIPLE DEPENDENT CLAIM			\$130	\$	\$260	\$0
ADDITIONAL FILING FEE					\$	\$0
TOTAL FILING FEE DUE					\$	\$2178.00

- A Check is enclosed in the amount of \$ 2178.00 .
- The Commissioner is authorized to charge payment of the following fees and to refund any overpayment associated with this communication or during the pendency of this application to deposit account 23-3050. This sheet is provided in duplicate.
- The foregoing amount due.
- Any additional filing fees required, including fees for the presentation of extra claims under 37 C.F.R. 1.16.
- Any additional patent application processing fees under 37 C.F.R. 1.17 or 1.20(d).
- The issue fee set in 37 C.F.R. 1.18 at the mailing of the Notice of Allowance.
- The Commissioner is hereby requested to grant an extension of time for the appropriate length of time, should one be necessary, in connection with this filing or any future filing submitted to the U.S. Patent and Trademark Office in the above-

00360" E4SF360

identified application during the pendency of this application. The Commissioner is further authorized to charge any fees related to any such extension of time to deposit account 23-3050. This sheet is provided in duplicate.

**SHOULD ANY DEFICIENCIES APPEAR** with respect to this application, including deficiencies in payment of fees, missing parts of the application or otherwise, the United States Patent and Trademark Office is respectfully requested to promptly notify the undersigned.

Date:

Sept. 28, 2000

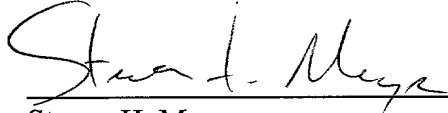

Steven H. Meyer  
Registration No. 37,189

Woodcock Washburn Kurtz  
Mackiewicz & Norris LLP  
One Liberty Place - 46th Floor  
Philadelphia PA 19103  
Telephone: (215) 568-3100  
Facsimile: (215) 568-3439

000000000000000000000000

Express mail No.  
EL531429456US

5

**Title of the Invention**

10 Retail Transactions Involving Distributed and Super-Distributed Digital Content in  
a Digital Rights Management (DRM) System

**Cross-Reference to Related Application**

This application is related to U.S. Patent Application No.

15 09/290,363, filed April 12, 1999 and entitled "ENFORCEMENT ARCHITECTURE  
AND METHOD FOR DIGITAL RIGHTS MANAGEMENT", and U.S. Provisional  
Application No. 60/126,614, filed March 27, 1999 and entitled "ENFORCEMENT  
ARCHITECTURE AND METHOD FOR DIGITAL RIGHTS MANAGEMENT", both  
of which are hereby incorporated by reference.

20 This application is related to and filed concurrently with: U.S. Patent  
Application No. 09/\_\_\_\_,\_\_\_\_, Attorney Docket No. MSFT-0180 / 138333.1, entitled  
"Retail Transactions Involving Digital Content in a Digital Rights Management  
(DRM) System" which is hereby incorporated by reference.

25

**Technical Field**

The present invention relates to an architecture for enforcing rights  
in digital content. More specifically, the present invention relates to such an  
enforcement architecture that allows access to encrypted digital content only in

09/290,363







making a copy of such digital content, except as otherwise allowed for by the content owner thereof.

### Summary of the Invention

5           In the present invention, to distribute digital content from a retailer to a customer, the content as issued by a content provider is retrieved. The as issued content has license acquisition information for acquiring a corresponding license attached thereto, where the license acquisition information includes a site identifier identifying a site at which the customer may obtain a digital license  
10           corresponding to the content. The site identifier includes an additional information field attached thereto.

          The additional information field is modified to include retailer information identifying the retailer, and the content is delivered with the modified additional information field to the customer. Thus, a license request sent from the  
15           customer is addressed to the site identified by the site identifier in the license acquisition information and includes the modified additional information field attached thereto.

          The corresponding digital license is issued to the customer after receiving the license request at the site identified by the site identifier, and after  
20           payment is received at such site from the customer in connection with the license request. In particular, the retailer information from the license request is retrieved and the retailer is identified therefrom, and such identified retailer is credited for a portion of the payment received.

### 25           Brief Description of the Drawings

          The foregoing summary, as well as the following detailed description of the embodiments of the present invention, will be better understood when read in conjunction with the appended drawings. For the purpose of illustrating the invention, there are shown in the drawings embodiments which are presently

preferred. As should be understood, however, the invention is not limited to the precise arrangements and instrumentalities shown. In the drawings:

Fig. 1 is a block diagram showing an enforcement architecture in accordance with one embodiment of the present invention;

5 Fig. 2 is a block diagram of the authoring tool of the architecture of Fig. 1 in accordance with one embodiment of the present invention;

Fig. 3 is a block diagram of a digital content package having digital content for use in connection with the architecture of Fig. 1 in accordance with one embodiment of the present invention;

10 Fig. 4 is a block diagram of the user's computing device of Fig. 1 in accordance with one embodiment of the present invention;

Figs. 5A and 5B are flow diagrams showing the steps performed in connection with the Digital Rights Management (DRM) system of the computing device of Fig. 4 to render content in accordance with one embodiment of the present invention;

15 Fig. 6 is a flow diagram showing the steps performed in connection with the DRM system of Fig. 4 to determine whether any valid, enabling licenses are present in accordance with one embodiment of the present invention;

20 Fig. 7 is a flow diagram showing the steps performed in connection with the DRM system of Fig. 4 to obtain a license in accordance with one embodiment of the present invention;

Fig. 8 is a block diagram of a digital license for use in connection with the architecture of Fig. 1 in accordance with one embodiment of the present invention;

25 Fig. 9 is a flow diagram showing the steps performed in connection with the DRM system of Fig. 4 to obtain a new black box in accordance with one embodiment of the present invention;

Fig. 10 is a flow diagram showing the key transaction steps performed in connection with the DRM system of Fig. 4 to validate a license and a

piece of digital content and render the content in accordance with one embodiment of the present invention;

Fig. 11 is a block diagram showing the license evaluator of Fig. 4 along with a Digital Rights License (DRL) of a license and a language engine for interpreting the DRL in accordance with one embodiment of the present invention;

Fig. 12 is a block diagram representing a general purpose computer system in which aspects of the present invention and/or portions thereof may be incorporated;

Fig. 13 is a block diagram representing an arrangement wherein a customer obtains content distributed from a retailer, pays a license server, and obtains a license from the license server in accordance with one embodiment of the present invention;

Fig. 14 is a flow diagram showing steps performed in connection with the arrangement of Fig. 13;

Fig. 15 is a block diagram representing an arrangement wherein a customer obtains content distributed from a retailer, pays the retailer, and obtains a license from a license server in accordance with one embodiment of the present invention; and

Fig. 16 is a flow diagram showing steps performed in connection with the arrangement of Fig. 15.

### **Detailed Description of the Invention**

Referring to the drawings in details, wherein like numerals are used to indicate like elements throughout, there is shown in Fig. 1 an enforcement architecture 10 in accordance with one embodiment of the present invention. Overall, the enforcement architecture 10 allows an owner of digital content 12 to specify license rules that must be satisfied before such digital content 12 is allowed to be rendered on a user's computing device 14. Such license rules are embodied within a digital license 16 that the user / user's computing device 14 (hereinafter, such terms are interchangeable unless circumstances require

otherwise) must obtain from the content owner or an agent thereof. The digital content 12 is distributed in an encrypted form, and may be distributed freely and widely. Preferably, the decrypting key (KD) for decrypting the digital content 12 is included with the license 16.

5

#### COMPUTER ENVIRONMENT

Fig. 12 and the following discussion are intended to provide a brief general description of a suitable computing environment in which the present invention and/or portions thereof may be implemented. Although not required, the invention is described in the general context of computer-executable instructions, such as program modules, being executed by a computer, such as a client workstation or a server. Generally, program modules include routines, programs, objects, components, data structures and the like that perform particular tasks or implement particular abstract data types. Moreover, it should be appreciated that the invention and/or portions thereof may be practiced with other computer system configurations, including hand-held devices, multi-processor systems, microprocessor-based or programmable consumer electronics, network PCs, minicomputers, mainframe computers and the like. The invention may also be practiced in distributed computing environments where tasks are performed by remote processing devices that are linked through a communications network. In a distributed computing environment, program modules may be located in both local and remote memory storage devices.

As shown in Fig. 12, an exemplary general purpose computing system includes a conventional personal computer 120 or the like, including a processing unit 121, a system memory 122, and a system bus 123 that couples various system components including the system memory to the processing unit 121. The system bus 123 may be any of several types of bus structures including a memory bus or memory controller, a peripheral bus, and a local bus using any of a variety of bus architectures. The system memory includes read-only memory (ROM) 124 and random access memory (RAM) 125. A basic input/output system

126 (BIOS), containing the basic routines that help to transfer information between elements within the personal computer 120, such as during start-up, is stored in ROM 124.

The personal computer 120 may further include a hard disk drive 5 127 for reading from and writing to a hard disk (not shown), a magnetic disk drive 128 for reading from or writing to a removable magnetic disk 129, and an optical disk drive 130 for reading from or writing to a removable optical disk 131 such as a CD-ROM or other optical media. The hard disk drive 127, magnetic disk drive 128, and optical disk drive 130 are connected to the system bus 123 by a hard 10 disk drive interface 132, a magnetic disk drive interface 133, and an optical drive interface 134, respectively. The drives and their associated computer-readable media provide non-volatile storage of computer readable instructions, data structures, program modules and other data for the personal computer 120.

Although the exemplary environment described herein employs a 15 hard disk, a removable magnetic disk 129, and a removable optical disk 131, it should be appreciated that other types of computer readable media which can store data that is accessible by a computer may also be used in the exemplary operating environment. Such other types of media include a magnetic cassette, a flash memory card, a digital video disk, a Bernoulli cartridge, a random access 20 memory (RAM), a read-only memory (ROM), and the like.

A number of program modules may be stored on the hard disk, magnetic disk 129, optical disk 131, ROM 124 or RAM 125, including an operating system 135, one or more application programs 136, other program modules 137 and program data 138. A user may enter commands and information into the 25 personal computer 120 through input devices such as a keyboard 140 and pointing device 142. Other input devices (not shown) may include a microphone, joystick, game pad, satellite disk, scanner, or the like. These and other input devices are often connected to the processing unit 121 through a serial port interface 146 that is coupled to the system bus, but may be connected by other 30 interfaces, such as a parallel port, game port, or universal serial bus (USB). A

00000179-1

monitor 147 or other type of display device is also connected to the system bus 123 via an interface, such as a video adapter 148. In addition to the monitor 147, a personal computer typically includes other peripheral output devices (not shown), such as speakers and printers. The exemplary system of Fig. 12 also  
5 includes a host adapter 155, a Small Computer System Interface (SCSI) bus 156, and an external storage device 162 connected to the SCSI bus 156.

The personal computer 120 may operate in a networked environment using logical connections to one or more remote computers, such as a remote computer 149. The remote computer 149 may be another personal  
10 computer, a server, a router, a network PC, a peer device or other common network node, and typically includes many or all of the elements described above relative to the personal computer 120, although only a memory storage device 150 has been illustrated in Fig. 12. The logical connections depicted in Fig. 12 include a local area network (LAN) 151 and a wide area network (WAN) 152.  
15 Such networking environments are commonplace in offices, enterprise-wide computer networks, intranets, and the Internet.

When used in a LAN networking environment, the personal computer 120 is connected to the LAN 151 through a network interface or adapter 153. When used in a WAN networking environment, the personal computer 120  
20 typically includes a modem 154 or other means for establishing communications over the wide area network 152, such as the Internet. The modem 154, which may be internal or external, is connected to the system bus 123 via the serial port interface 146. In a networked environment, program modules depicted relative to the personal computer 120, or portions thereof, may be stored in the remote  
25 memory storage device. It will be appreciated that the network connections shown are exemplary and other means of establishing a communications link between the computers may be used.

## ARCHITECTURE

Referring again to Fig. 1, in one embodiment of the present invention, the architecture 10 includes an authoring tool 18, a content-key database 20, a content server 22, a license server 24, and a black box server 26,  
5 as well as the aforementioned user's computing device 14.

## ARCHITECTURE - Authoring Tool 18

The authoring tool 18 is employed by a content owner to package a piece of digital content 12 into a form that is amenable for use in connection with  
10 the architecture 10 of the present invention. In particular, the content owner provides the authoring tool 18 with the digital content 12, instructions and/or rules that are to accompany the digital content 12, and instructions and/or rules as to how the digital content 12 is to be packaged. The authoring tool 18 then produces a digital content package 12p having the digital content 12 encrypted  
15 according to an encryption / decryption key, and the instructions and/or rules that accompany the digital content 12.

In one embodiment of the present invention, the authoring tool 18 is instructed to serially produce several different digital content 12 packages 12p, each having the same digital content 12 encrypted according to a different  
20 encryption / decryption key. As should be understood, having several different packages 12p with the same digital content 12 may be useful for tracking the distribution of such packages 12p / content 12 (hereinafter simply "digital content 12", unless circumstances require otherwise). Such distribution tracking is not ordinarily necessary, but may be used by an investigative authority in cases  
25 where the digital content 12 has been illegally sold or broadcast.

In one embodiment of the present invention, the encryption / decryption key that encrypts the digital content 12 is a symmetric key, in that the encryption key is also the decryption key (KD). As will be discussed below in more detail, such decryption key (KD) is delivered to a user's computing device  
30 14 in a hidden form as part of a license 16 for such digital content 12. Preferably,



each piece of digital content 12 is provided with a content ID (or each package 12p is provided with a package ID), each decryption key (KD) has a key ID, and the authoring tool 18 causes the decryption key (KD), key ID, and content ID (or package ID) for each piece of digital content 12 (or each package 12p) to be  
5 stored in the content-key database 20. In addition, license data regarding the types of licenses 16 to be issued for the digital content 12 and the terms and conditions for each type of license 16 may be stored in the content-key database 20, or else in another database (not shown). Preferably, the license data can be modified by the content owner at a later time as circumstances and market  
10 conditions may require.

In use, the authoring tool 18 is supplied with information including, among other things:

- the digital content 12 to be packaged;
- the type and parameters of watermarking and/or fingerprinting to  
15 be employed, if any;
- the type and parameters of data compression to be employed, if any;
- the type and parameters of encryption to be employed;
- the type and parameters of serialization to be employed, if any;
- 20 and
- the instructions and/or rules that are to accompany the digital content 12.

As is known, a watermark is a hidden, computer-readable signal that is added to the digital content 12 as an identifier. A fingerprint is a watermark that  
25 is different for each instance. As should be understood, an instance is a version of the digital content 12 that is unique. Multiple copies of any instance may be made, and any copy is of a particular instance. When a specific instance of digital content 12 is illegally sold or broadcast, an investigative authority can perhaps identify suspects according to the watermark / fingerprint added to such digital  
30 content 12.

Data compression may be performed according to any appropriate compression algorithm without departing from the spirit and scope of the present invention. For example, the .mp3 or .wav compression algorithm may be employed. Of course, the digital content 12 may already be in a compressed state, in which case no additional compression is necessary.

The instructions and/or rules that are to accompany the digital content 12 may include practically any appropriate instructions, rules, or other information without departing from the spirit and scope of the present invention. As will be discussed below, such accompanying instructions / rules / information are primarily employed by the user and the user's computing device 14 to obtain a license 16 to render the digital content 12. Accordingly, such accompanying instructions / rules / information may include an appropriately formatted license acquisition script or the like, as will be described in more detail below. In addition, or in the alternative, such accompanying instructions / rules / information may include 'preview' information designed to provide a user with a preview of the digital content 12.

With the supplied information, the authoring tool 18 then produces one or more packages 12p corresponding to the digital content 12. Each package 12p may then be stored on the content server 22 for distribution to the world.

In one embodiment of the present invention, and referring now to Fig. 2, the authoring tool 18 is a dynamic authoring tool 18 that receives input parameters which can be specified and operated on. Accordingly, such authoring tool 18 can rapidly produce multiple variations of package 12p for multiple pieces of digital content 12. Preferably, the input parameters are embodied in the form of a dictionary 28, as shown, where the dictionary 28 includes such parameters as:

- the name of the input file 29a having the digital content 12;
- the type of encoding that is to take place
- the encryption / decryption key (KD) to be employed,

- the accompanying instructions / rules / information ('header information') to be packaged with the digital content 12 in the package 12p.
  - the type of muxing that is to occur; and
  - the name of the output file 29b to which the package 12p based on
- 5 the digital content 12 is to be written.

As should be understood, such dictionary 28 is easily and quickly modifiable by an operator of the authoring tool 18 (human or machine), and therefore the type of authoring performed by the authoring tool 18 is likewise easily and quickly modifiable in a dynamic manner. In one embodiment of the

10 present invention, the authoring tool 18 includes an operator interface (not shown) displayable on a computer screen to a human operator. Accordingly, such operator may modify the dictionary 28 by way of the interface, and further may be appropriately aided and/or restricted in modifying the dictionary 28 by way of the interface.

15 In the authoring tool 18, and as seen in Fig. 2, a source filter 18a receives the name of the input file 29a having the digital content 12 from the dictionary 28, and retrieves such digital content 12 from such input file and places the digital content 12 into a memory 29c such as a RAM or the like. An encoding filter 18b then performs encoding on the digital content 12 in the memory 29c to

20 transfer the file from the input format to the output format according to the type of encoding specified in the dictionary 28 (i.e., .wav to .asp, .mp3 to .asp, etc.), and places the encoded digital content 12 in the memory 29c. As shown, the digital content 12 to be packaged (music, e.g.) is received in a compressed format such as the .wav or .mp3 format, and is transformed into a format such as the .asp

25 (active streaming protocol) format. Of course, other input and output formats may be employed without departing from the spirit and scope of the present invention.

Thereafter, an encryption filter 18c encrypts the encoded digital content 12 in the memory 29c according to the encryption / decryption key (KD) specified in the dictionary 28, and places the encrypted digital content 12 in the

000000000000000000000000

memory 29c. A header filter 18d then adds the header information specified in the dictionary 28 to the encrypted digital content 12 in the memory 29c.

As should be understood, depending on the situation, the package 12p may include multiple streams of temporally aligned digital content 12 (one stream being shown in Fig. 2), where such multiple streams are multiplexed (i.e., 'muted'). Accordingly, a mux filter 18e performs muxing on the header information and encrypted digital content 12 in the memory 29c according to the type of muxing specified in the dictionary 28, and places the result in the memory 29c. A file writer filter 18f then retrieves the result from the memory 29c and writes such result to the output file 29b specified in the dictionary 28 as the package 12p.

It should be noted that in certain circumstances, the type of encoding to be performed will not normally change. Since the type of muxing typically is based on the type of encoding, it is likewise the case that the type of muxing will not normally change, either. If this is in fact the case, the dictionary 28 need not include parameters on the type of encoding and/or the type of muxing. Instead, it is only necessary that the type of encoding be 'hardwired' into the encoding filter and/or that the type of muxing be 'hardwired' into the mux filter. Of course, as circumstance require, the authoring tool 18 may not include all of the aforementioned filters, or may include other filters, and any included filter may be hardwired or may perform its function according to parameters specified in the dictionary 28, all without departing from the spirit and scope of the present invention.

Preferably, the authoring tool 18 is implemented on an appropriate computer, processor, or other computing machine by way of appropriate software. The structure and operation of such machine and such software should be apparent based on the disclosure herein and therefore do not require any detailed discussion in the present disclosure.

## ARCHITECTURE - Content Server 22

Referring again to Fig. 1, in one embodiment of the present invention, the content server 22 distributes or otherwise makes available for retrieval the packages 12p produced by the authoring tool 18. Such packages  
5 12p may be distributed as requested by the content server 22 by way of any appropriate distribution channel without departing from the spirit and scope of the present invention. For example, such distribution channel may be the Internet or another network, an electronic bulletin board, electronic mail, or the like. In addition, the content server 22 may be employed to copy the packages 12p onto  
10 magnetic or optical disks or other storage devices, and such storage devices may then be distributed.

It will be appreciated that the content server 22 distributes packages 12p without regard to any trust or security issues. As discussed below, such issues are dealt with in connection with the license server 24 and the relationship  
15 between such license server 24 and the user's computing device 14. In one embodiment of the present invention, the content server 22 freely releases and distributes packages 12p having digital content 12 to any distributee requesting same. However, the content server 22 may also release and distribute such packages 12p in a restricted manner without departing from the spirit and scope  
20 of the present invention. For example, the content server 22 may first require payment of a pre-determined distribution fee prior to distribution, or may require that a distributee identify itself, or may indeed make a determination of whether distribution is to occur based on an identification of the distributee.

In addition, the content server 22 may be employed to perform  
25 inventory management by controlling the authoring tool 18 to generate a number of different packages 12p in advance to meet an anticipated demand. For example, the server could generate 100 packages 12p based on the same digital content 12, and serve each package 12p 10 times. As supplies of packages 12p dwindle to 20, for example, the content server 22 may then direct the authoring  
30 tool 18 to generate 80 additional packages 12p, again for example.

00000-000000

5 Preferably, the content server 22 in the architecture 10 has a unique public / private key pair (PU-CS, PR-CS) that is employed as part of the process of evaluating a license 16 and obtaining a decryption key (KD) for decrypting corresponding digital content 12, as will be explained in more detail below. As is known, a public / private key pair is an asymmetric key, in that what is encrypted in one of the keys in the key pair can only be decrypted by the other of the keys in the key pair. In a public / private key pair encryption system, the public key may be made known to the world, but the private key should always be held in confidence by the owner of such private key. Accordingly, if the content server 22  
10 encrypts data with its private key (PR-CS), it can send the encrypted data out into the world with its public key (PU-CS) for decryption purposes. Correspondingly, if an external device wants to send data to the content server 22 so that only such content server 22 can decrypt such data, such external device must first obtain the public key of the content server 22 (PU-CS) and then must encrypt the data with such public key. Accordingly, the content server 22 (and only the content  
15 server 22) can then employ its private key (PR-CS) to decrypt such encrypted data.

As with the authoring tool 18, the content server 22 is implemented on an appropriate computer, processor, or other computing machine by way of  
20 appropriate software. The structure and operation of such machine and such software should be apparent based on the disclosure herein and therefore do not require any detailed discussion in the present disclosure. Moreover, in one embodiment of the present invention, the authoring tool 18 and the content server 22 may reside on a single computer, processor, or other computing machine,  
25 each in a separate work space. It should be recognized, moreover, that the content server 22 may in certain circumstances include the authoring tool 18 and/or perform the functions of the authoring tool 18, as discussed above.

Structure of Digital Content Package 12p

Referring now to Fig. 3, in one embodiment of the present invention, the digital content package 12p as distributed by the content server 22 includes:

- 5 - the digital content 12 encrypted with the encryption / decryption key (KD), as was discussed above (i.e., (KD(CONTENT)));
- the content ID (or package ID) of such digital content 12 (or package 12p);
- the key ID of the decryption key (KD);
- license acquisition information, preferably in an un-encrypted form;
- 10 and
- the key KD encrypting the content server 22 public key (PU-CS), signed by the content server 22 private key (PR-CS) (i.e., (KD (PU-CS) S (PR-CS))).

With regard to (KD (PU-CS) S (PR-CS)), it is to be understood that such item is to be used in connection with validating the digital content 12 and/or package 12p, as will be explained below. Unlike a certificate with a digital signature (see below), the key (PU-CS) is not necessary to get at (KD (PU-CS)). Instead, the key (PU-CS) is obtained merely by applying the decryption key (KD). Once so obtained, such key (PU-CS) may be employed to test the validity of the signature (S (PR-CS)).

It should also be understood that for such package 12p to be constructed by the authoring tool 18, such authoring tool 18 must already possess the license acquisition information and (KD (PU-CS) S (PR-CS)), presumably as header information supplied by the dictionary 28. Moreover, the authoring tool 18 and the content server 22 must presumably interact to construct (KD (PU-CS) S (PR-CS)). Such interaction may for example include the steps of:

- the content server 22 sending (PU-CS) to the authoring tool 18;
- the authoring tool 18 encrypting (PU-CS) with (KD) to produce (KD (PU-CS));

000001 000001 000001 000001 000001 000001

- the authoring tool 18 sending (KD (PU-CS)) to the content server 22;

- the content server 22 signing (KD (PU-CS)) with (PR-CS) to produce (KD (PU-CS) S (PR-CS)); and

5 - the content server 22 sending (KD (PU-CS) S (PR-CS)) to the authoring tool 18.

#### ARCHITECTURE - License Server 24

Referring again to Fig. 1, in one embodiment of the present invention, the license server 24 performs the functions of receiving a request for a license 16 from a user's computing device 14 in connection with a piece of digital content 12, determining whether the user's computing device 14 can be trusted to honor an issued license 16, negotiating such a license 16, constructing such license 16, and transmitting such license 16 to the user's computing device 14.  
15 Preferably, such transmitted license 16 includes the decryption key (KD) for decrypting the digital content 12. Such license server 24 and such functions will be explained in more detail below. Preferably, and like the content server 22, the license server 24 in the architecture 10 has a unique public / private key pair (PU-LS, PR-LS) that is employed as part of the process of evaluating a license 16 and  
20 obtaining a decryption key (KD) for decrypting corresponding digital content 12, as will be explained in more detail below.

As with the authoring tool 18 and the content server 22, the license server 24 is implemented on an appropriate computer, processor, or other computing machine by way of appropriate software. The structure and operation  
25 of such machine and such software should be apparent based on the disclosure herein and therefore do not require any detailed discussion in the present disclosure. Moreover, in one embodiment of the present invention the authoring tool 18 and/or the content server 22 may reside on a single computer, processor, or other computing machine together with the license server 24, each in a  
30 separate work space.



In one embodiment of the present invention, prior to issuance of a license 16, the license server 24 and the content server 22 enter into an agency agreement or the like, wherein the license server 24 in effect agrees to be the licensing authority for at least a portion of the digital content 12 distributed by the content server 22. As should be understood, one content server 22 may enter into an agency agreement or the like with several license servers 24, and/or one license server 24 may enter into an agency agreement or the like with several content servers 22, all without departing from the spirit and scope of the present invention.

Preferably, the license server 24 can show to the world that it does in fact have the authority to issue a license 16 for digital content 12 distributed by the content server 22. To do so, it is preferable that the license server 24 send to the content server 22 the license server 24 public key (PU-LS), and that the content server 22 then send to the license server 24 a digital certificate containing PU-LS as the contents signed by the content server 22 private key (CERT (PU-LS) S (PR-CS)). As should be understood, the contents (PU-LS) in such certificate can only be accessed with the content server 22 public key (PU-CS). As should also be understood, in general, a digital signature of underlying data is an encrypted form of such data, and will not match such data when decrypted if such data has been adulterated or otherwise modified.

As a licensing authority in connection with a piece of digital content 12, and as part of the licensing function, the license server 24 must have access to the decryption key (KD) for such digital content 12. Accordingly, it is preferable that license server 24 have access to the content-key database 20 that has the decryption key (KD), key ID, and content ID (or package ID) for such digital content 12 (or package 12p).

#### ARCHITECTURE - Black Box Server 26

Still referring to Fig. 1, in one embodiment of the present invention, the black box server 26 performs the functions of installing and/or upgrading a



owner, i.e. that the digital content 12 will not be rendered unless the user obtains a license 16 that permits the rendering in the manner sought. Preferably, then, the user's computing device 14 must provide a trusted component or mechanism 32 that can satisfy to the content owner that such computing device 14 will not  
 5 render the digital content 12 except according to the license rules embodied in the license 16 associated with the digital content 12 and obtained by the user.

Here, the trusted mechanism 32 is a Digital Rights Management (DRM) system 32 that is enabled when a user requests that a piece of digital content 12 be rendered, that determines whether the user has a license 16 to  
 10 render the digital content 12 in the manner sought, that effectuates obtaining such a license 16 if necessary, that determines whether the user has the right to play the digital content 12 according to the license 16, and that decrypts the digital content 12 for rendering purposes if in fact the user has such right according to such license 16. The contents and function of the DRM system 32 on the user's  
 15 computing device 14 and in connection with the architecture 10 are described below.

#### DRM SYSTEM 32

The DRM system 32 performs four main functions with the  
 20 architecture 10 disclosed herein: (1) content acquisition, (2) license acquisition, (3) content rendering, and (4) black box 30 installation / update. Preferably, any of the functions can be performed at any time, although it is recognized that some of the functions already require that digital content 12 be acquired.

#### 25 DRM SYSTEM 32 - Content Acquisition

Acquisition of digital content 12 by a user and/or the user's computing device 14 is typically a relatively straight-forward matter and generally involves placing a file having encrypted digital content 12 on the user's computing device 14. Of course, to work with the architecture 10 and the DRM system 32



DRM SYSTEM 32 - Content Rendering, Part 1

Referring now to Fig. 5A, in one embodiment of the present invention, assuming the encrypted digital content 12 has been distributed to and received by a user and placed by the user on the computing device 14 in the form of a stored file, the user will attempt to render the digital content 12 by executing some variation on a render command (step 501). For example, such render command may be embodied as a request to ‘play’ or ‘open’ the digital content 12. In some computing environments, such as for example the “MICROSOFT WINDOWS” operating system, distributed by MICROSOFT Corporation of Redmond, Washington, such play or open command may be as simple as ‘clicking’ on an icon representative of the digital content 12. Of course, other embodiments of such render command may be employed without departing from the spirit and scope of the present invention. In general, such render command may be considered to be executed whenever a user directs that a file having digital content 12 be opened, run, executed, and/or the like.

Importantly, and in addition, such render command may be embodied as a request to copy the digital content 12 to another form, such as to a printed form, a visual form, an audio form, etc. As should be understood, the same digital content 12 may be rendered in one form, such as on a computer screen, and then in another form, such as a printed document. In the present invention, each type of rendering is performed only if the user has the right to do so, as will be explained below.

In one embodiment of the present invention, the digital content 12 is in the form of a digital file having a file name ending with an extension, and the computing device 14 can determine based on such extension to start a particular kind of rendering application 34. For example, if the file name extension indicates that the digital content 12 is a text file, the rendering application 34 is some form of word processor such as the “MICROSOFT WORD”, distributed by MICROSOFT Corporation of Redmond, Washington. Likewise, if the file name extension indicates that the digital content 12 is an audio, video, and/or

00000"EHF&90

5  
10  
15  
20  
25  
30

multimedia file, the rendering application 34 is some form of multimedia player, such as “MICROSOFT MEDIA PLAYER”, also distributed by MICROSOFT Corporation of Redmond, Washington.

5 Of course, other methods of determining a rendering application may be employed without departing from the spirit and scope of the present invention. As but one example, the digital content 12 may contain meta-data in an un-encrypted form (i.e., the aforementioned header information), where the meta-data includes information on the type of rendering application 34 necessary to render such digital content 12.

10 Preferably, such rendering application 34 examines the digital content 12 associated with the file name and determines whether such digital content 12 is encrypted in a rights-protected form (steps 503, 505). If not protected, the digital content 12 may be rendered without further ado (step 507). If protected, the rendering application 34 determines from the encrypted digital content 12 that the DRM system 32 is necessary to play such digital content 12. Accordingly, such rendering application 34 directs the user's computing device 14 to run the DRM system 32 thereon (step 509). Such rendering application 34 then calls such DRM system 32 to decrypt the digital content 12 (step 511). As will be discussed in more detail below, the DRM system 32 in fact decrypts the digital content 12 only if the user has a valid license 16 for such digital content 12 and the right to play the digital content 12 according to the license rules in the valid license 16. Preferably, once the DRM system 32 has been called by the rendering application 34, such DRM system 32 assumes control from the rendering application 34, at least for purposes of determining whether the user 25 has a right to play such digital content 12 (step 513).

### DRM System 32 Components

In one embodiment of the present invention, and referring again to Fig. 4, the DRM system 32 includes a license evaluator 36, the black box 30, a license store 38, and a state store 40.

30

## DRM System 32 Components - License Evaluator 36

5 The license evaluator 36 locates one or more licenses 16 that correspond to the requested digital content 12, determines whether such licenses 16 are valid, reviews the license rules in such valid licenses 16, and determines based on the reviewed license rules whether the requesting user has the right to render the requested digital content 12 in the manner sought, among other things. As should be understood, the license evaluator 36 is a trusted component in the DRM system 32. In the present disclosure, to be 'trusted' means that the license server 24 (or any other trusting element) is satisfied that the trusted element will carry out the wishes of the owner of the digital content 12 according to the rights description in the license 16, and that a user cannot easily alter such trusted element for any purpose, nefarious or otherwise.

10 The license evaluator 36 has to be trusted in order to ensure that such license evaluator 36 will in fact evaluate a license 16 properly, and to ensure that such license evaluator 36 has not been adulterated or otherwise modified by a user for the purpose of bypassing actual evaluation of a license 16. Accordingly, the license evaluator 36 is run in a protected or shrouded environment such that the user is denied access to such license evaluator 36.  
15 Other protective measures may of course be employed in connection with the license evaluator 36 without departing from the spirit and scope of the present invention.

## 25 DRM System 32 Components - Black Box 30

Primarily, and as was discussed above, the black box 30 performs encryption and decryption functions in the DRM system 32. In particular, the black box 30 works in conjunction with the license evaluator 36 to decrypt and encrypt certain information as part of the license evaluation function. In addition, once the license evaluator 36 determines that a user does in fact have the right to

render the requested digital content 12 in the manner sought, the black box 30 is provided with a decryption key (KD) for such digital content 12, and performs the function of decrypting such digital content 12 based on such decryption key (KD).

The black box 30 is also a trusted component in the DRM system  
5 32. In particular, the license server 24 must trust that the black box 30 will perform the decryption function only in accordance with the license rules in the license 16, and also trust that such black box 30 will not operate should it become adulterated or otherwise modified by a user for the nefarious purpose of bypassing actual evaluation of a license 16. Accordingly, the black box 30 is also  
10 run in a protected or shrouded environment such that the user is denied access to such black box 30. Again, other protective measures may be employed in connection with the black box 30 without departing from the spirit and scope of the present invention. Preferably, and like the content server 22 and license server 24, the black box 30 in the DRM system 32 has a unique public / private  
15 key pair (PU-BB, PR-BB) that is employed as part of the process of evaluating the license 16 and obtaining a decryption key (KD) for decrypting the digital content 12, as will be described in more detail below.

#### DRM System 32 Components - License Store 38

20 The license store 38 stores licenses 16 received by the DRM system 32 for corresponding digital content 12. The license store 38 itself need not be trusted since the license store 38 merely stores licenses 16, each of which already has trust components built thereinto, as will be described below. In one embodiment of the present invention, the license store 38 is merely a sub-  
25 directory of a drive such as a hard disk drive or a network drive. However, the license store 38 may be embodied in any other form without departing from the spirit and scope of the present invention, so long as such license store 38 performs the function of storing licenses 16 in a location relatively convenient to the DRM system 32.

30



## DRM System 32 Components - State Store 40

The state store 40 performs the function of maintaining state information corresponding to licenses 16 presently or formerly in the license store 38. Such state information is created by the DRM system 32 and stored in the state store 40 as necessary. For example, if a particular license 16 only allows a pre-determined number of renderings of a piece of corresponding digital content 12, the state store 40 maintains state information on how many renderings have in fact taken place in connection with such license 16. The state store 40 continues to maintain state information on licenses 16 that are no longer in the license store 38 to avoid the situation where it would otherwise be advantageous to delete a license 16 from the license store 38 and then obtain an identical license 16 in an attempt to delete the corresponding state information from the state store 40.

The state store 40 also has to be trusted in order to ensure that the information stored therein is not reset to a state more favorable to a user. Accordingly, the state store 40 is likewise run in a protected or shrouded environment such that the user is denied access to such state store 40. Once again, other protective measures may of course be employed in connection with the state store 40 without departing from the spirit and scope of the present invention. For example, the state store 40 may be stored by the DRM system 32 on the computing device 14 in an encrypted form.

## DRM SYSTEM 32 - Content Rendering, Part 2

Referring again to Fig. 5A, and again discussing content rendering in one embodiment of the present invention, once the DRM system 32 has assumed control from the calling rendering application 34, such DRM system 32 then begins the process of determining whether the user has a right to render the requested digital content 12 in the manner sought. In particular, the DRM system 32 either locates a valid, enabling license 16 in the license store (steps 515, 517) or attempts to acquire a valid, enabling license 16 from the license server 24 (i.e.

performs the license acquisition function as discussed below and as shown in Fig. 7).

As a first step, and referring now to Fig. 6, the license evaluator 36 of such DRM system 32 checks the license store 38 for the presence of one or more received licenses 16 that correspond to the digital content 12 (step 601). Typically, the license 16 is in the form of a digital file, as will be discussed below, although it will be recognized that the license 16 may also be in other forms without departing from the spirit and scope of the present invention. Typically, the user will receive the digital content 12 without such license 16, although it will likewise be recognized that the digital content 12 may be received with a corresponding license 16 without departing from the spirit and scope of the present invention.

As was discussed above in connection with Fig. 3, each piece of digital content 12 is in a package 12p with a content ID (or package ID) identifying such digital content 12 (or package 12p), and a key ID identifying the decryption key (KD) that will decrypt the encrypted digital content 12. Preferably, the content ID (or package ID) and the key ID are in an un-encrypted form. Accordingly, and in particular, based on the content ID of the digital content 12, the license evaluator 36 looks for any license 16 in the license store 38 that contains an identification of applicability to such content ID. Note that multiple such licenses 16 may be found, especially if the owner of the digital content 12 has specified several different kinds of licenses 16 for such digital content 12, and the user has obtained multiple ones of such licenses 16. If in fact the license evaluator 36 does not find in the license store 38 any license 16 corresponding to the requested digital content 12, the DRM system 32 may then perform the function of license acquisition (step 519 of Fig. 5), to be described below.

Assume now that the DRM system 32 has been requested to render a piece of digital content 12, and one or more licenses 16 corresponding thereto are present in the license store 38. In one embodiment of the present invention, then, the license evaluator 36 of the DRM system 32 proceeds to determine for

each such license 16 whether such license 16 itself is valid (steps 603 and 605 of Fig. 6). Preferably, and in particular, each license 16 includes a digital signature 26 based on the content 28 of the license 16. As should be understood, the digital signature 26 will not match the license 16 if the content 28 has been

5 adulterated or otherwise modified. Thus, the license evaluator 36 can determine based on the digital signature 26 whether the content 28 is in the form that it was received from the license server 24 (i.e., is valid). If no valid license 16 is found in the license store 38, the DRM system 32 may then perform the license acquisition function described below to obtain such a valid license 16.

10 Assuming that one or more valid licenses 16 are found, for each valid license 16, the license evaluator 36 of the DRM system 32 next determines whether such valid license 16 gives the user the right to render the corresponding digital content 12 in the manner desired (i.e., is enabling) (steps 607 and 609). In particular, the license evaluator 36 determines whether the requesting user has

15 the right to play the requested digital content 12 based on the rights description in each license 16 and based on what the user is attempting to do with the digital content 12. For example, such rights description may allow the user to render the digital content 12 into a sound, but not into a decrypted digital copy.

As should be understood, the rights description in each license 16

20 specifies whether the user has rights to play the digital content 12 based on any of several factors, including who the user is, where the user is located, what type of computing device 14 the user is using, what rendering application 34 is calling the DRM system 32, the date, the time, etc. In addition, the rights description may limit the license 16 to a pre-determined number of plays, or pre-determined

25 play time, for example. In such case, the DRM system 32 must refer to any state information with regard to the license 16, (i.e., how many times the digital content 12 has been rendered, the total amount of time the digital content 12 has been rendered, etc.), where such state information is stored in the state store 40 of the DRM system 32 on the user's computing device 14.

003260 4972960

Accordingly, the license evaluator 36 of the DRM system 32 reviews the rights description of each valid license 16 to determine whether such valid license 16 confers the rights sought to the user. In doing so, the license evaluator 36 may have to refer to other data local to the user's computing device 14 to

5 perform a determination of whether the user has the rights sought. As seen in Fig. 4, such data may include an identification 42 of the user's computing device (machine) 14 and particular aspects thereof, an identification 44 of the user and particular aspects thereof, an identification of the rendering application 34 and particular aspects thereof, a system clock 46, and the like. If no valid license 16 is

10 found that provides the user with the right to render the digital content 12 in the manner sought, the DRM system 32 may then perform the license acquisition function described below to obtain such a license 16, if in fact such a license 16 is obtainable.

Of course, in some instances the user cannot obtain the right to

15 render the digital content 12 in the manner requested, because the content owner of such digital content 12 has in effect directed that such right not be granted. For example, the content owner of such digital content 12 may have directed that no license 16 be granted to allow a user to print a text document, or to copy a multimedia presentation into an un-encrypted form. In one embodiment of the

20 present invention, the digital content 12 includes data on what rights are available upon purchase of a license 16, and types of licenses 16 available. However, it will be recognized that the content owner of a piece of digital content 12 may at any time change the rights currently available for such digital content 12 by changing the licenses 16 available for such digital content 12.

25

#### DRM SYSTEM 32 - License Acquisition

Referring now to Fig. 7, if in fact the license evaluator 36 does not find in the license store 38 any valid, enabling license 16 corresponding to the requested digital content 12, the DRM system 32 may then perform the function of

30 license acquisition. As shown in Fig. 3, each piece of digital content 12 is

packaged with information in an un-encrypted form regarding how to obtain a license 16 for rendering such digital content 12 (i.e., license acquisition information).

In one embodiment of the present invention, such license acquisition information may include (among other things) types of licenses 16 available, and one or more Internet web sites or other site information at which one or more appropriate license servers 24 may be accessed, where each such license server 24 is in fact capable of issuing a license 16 corresponding to the digital content 12. Of course, the license 16 may be obtained in other manners without departing from the spirit and scope of the present invention. For example, the license 16 may be obtained from a license server 24 at an electronic bulletin board, or even in person or via regular mail in the form of a file on a magnetic or optical disk or the like.

Assuming that the location for obtaining a license 16 is in fact a license server 24 on a network, the license evaluator 36 then establishes a network connection to such license server 24 based on the web site or other site information, and then sends a request for a license 16 from such connected license server 24 (steps 701, 703). In particular, once the DRM system 32 has contacted the license server 24, such DRM system 32 transmits appropriate license request information 36 to such license server 24. In one embodiment of the present invention, such license 16 request information 36 may include:

- the public key of the black box 30 of the DRM system 32 (PU-BB);
- the version number of the black box 30 of the DRM system 32;
- a certificate with a digital signature from a certifying authority certifying the black box 30 (where the certificate may in fact include the aforementioned public key and version number of the black box 30);
- the content ID (or package ID) that identifies the digital content 12 (or package 12p);
- the key ID that identifies the decryption key (KD) for decrypting the digital content 12;

- the type of license 16 requested (if in fact multiple types are available);

- the type of rendering application 34 that requested rendering of the digital content 12;

5 and/or the like, among other things. Of course, greater or lesser amounts of license 16 request information 36 may be transmitted to the license server 24 by the DRM system 32 without departing from the spirit and scope of the present invention. For example, information on the type of rendering application 34 may not be necessary, while additional information about the user and/or the user's computing device 14 may be necessary.

10

Once the license server 24 has received the license 16 request information 36 from the DRM system 32, the license server 24 may then perform several checks for trust / authentication and for other purposes. In one embodiment of the present invention, such license server 24 checks the certificate with the digital signature of the certifying authority to determine whether such has been adulterated or otherwise modified (steps 705, 707). If so, the license server 24 refuses to grant any license 16 based on the request information 36. The license server 24 may also maintain a list of known 'bad' users and/or user's computing devices 14, and may refuse to grant any license 16 based on a request from any such bad user and/or bad user's computing device 14 on the list. Such 'bad' list may be compiled in any appropriate manner without departing from the spirit and scope of the present invention.

15

20

Based on the received request and the information associated therewith, and particularly based on the content ID (or package ID) in the license request information, the license server 24 can interrogate the content-key database 20 (Fig. 1) and locate a record corresponding to the digital content 12 (or package 12p) that is the basis of the request. As was discussed above, such record contains the decryption key (KD), key ID, and content ID for such digital content 12. In addition, such record may contain license data regarding the types of licenses 16 to be issued for the digital content 12 and the terms and conditions

25

30

for each type of license 16. Alternatively, such record may include a pointer, link, or reference to a location having such additional information.

As mentioned above, multiple types of licenses 16 may be available. For example, for a relatively small license fee, a license 16 allowing a limited number of renderings may be available. For a relatively greater license fee, a license 16 allowing unlimited renderings until an expiration date may be available. For a still greater license fee, a license 16 allowing unlimited renderings without any expiration date may be available. Practically any type of license 16 having any kind of license terms may be devised and issued by the license server 24 without departing from the spirit and scope of the present invention.

In one embodiment of the present invention, the request for a license 16 is accomplished with the aid of a web page or the like as transmitted from the license server 24 to the user's computing device 14. Preferably, such web page includes information on all types of licenses 16 available from the license server 24 for the digital content 12 that is the basis of the license 16 request.

In one embodiment of the present invention, prior to issuing a license 16, the license server 24 checks the version number of the black box 30 to determine whether such black box 30 is relatively current (steps 709, 711). As should be understood, the black box 30 is intended to be secure and protected from attacks from a user with nefarious purposes (i.e., to improperly render digital content 12 without a license 16, or outside the terms of a corresponding license 16). However, it is to be recognized that no system and no software device is in fact totally secure from such an attack.

As should also be understood, if the black box 30 is relatively current, i.e., has been obtained or updated relatively recently, it is less likely that such black box 30 has been successfully attacked by such a nefarious user. Preferably, and as a matter of trust, if the license server 24 receives a license request with request information 36 including a black box 30 version number that is not relatively current, such license server 24 refuses to issue the requested

00000000-20250310





As should be understood, depending on the circumstances, the license negotiation may require that the user provide further information to the license server 24 (for example, information on the user, the user's computing device 14, etc.). Importantly, the license negotiation may also require that the user and the license server 24 determine a mutually acceptable payment instrument (a credit account, a debit account, a mailed check, etc.) and/or payment method (paid-up immediately, spread over a period of time, etc.), among other things.

Once all the terms of the license 16 have been negotiated and agreed to by both the license server 24 and user (step 715), a digital license 16 is generated by the license server 24 (step 719), where such generated license 16 is based at least in part on the license request, the black box 30 public key (PU-BB), and the decryption key (KD) for the digital content 12 that is the basis of the request as obtained from the content-key database 20. In one embodiment of the present invention, and as seen in Fig. 8, the generated license 16 includes:

- the content ID of the digital content 12 to which the license 16 applies;
- a Digital Rights License (DRL) 48 (i.e., the rights description or actual terms and conditions of the license 16 written in a predetermined form that the license evaluator 36 can interrogate), perhaps encrypted with the decryption key (KD) (i.e., KD (DRL));
- the decryption key (KD) for the digital content 12 encrypted with the black box 30 public key (PU-BB) as receive in the license request (i.e.,(PU-BB (KD)));
- a digital signature from the license server 24 (without any attached certificate) based on (KD (DRL)) and (PU-BB (KD)) and encrypted with the license server 24 private key (i.e., (S (PR-LS))); and
- the certificate that the license server 24 obtained previously from the content server 22, such certificate indicating that the license server 24 has the

authority from the content server 22 to issue the license 16 (i.e., (CERT (PU-LS) S (PR-CS))).

As should be understood, the aforementioned elements and perhaps others are packaged into a digital file or some other appropriate form. As  
5 should also be understood, if the DRL 48 or (PU-BB (KD)) in the license 16 should become adulterated or otherwise modified, the digital signature (S (PR-LS)) in the license 16 will not match and therefore will not validate such license 16. For this reason, the DRL 48 need not necessarily be in an encrypted form (i.e., (KD(DRL)) as mentioned above), although such encrypted form may in  
10 some instances be desirable and therefore may be employed without departing from the spirit and scope of the present invention.

Once the digital license 16 has been prepared, such license 16 is then issued to the requestor (i.e., the DRM system 32 on the user's computing device 14) (step 719 of Fig. 7). Preferably, the license 16 is transmitted over the  
15 same path through which the request therefor was made (i.e., the Internet or another network), although another path may be employed without departing from the spirit and scope of the present invention. Upon receipt, the requesting DRM system 32 preferably automatically places the received digital license 16 in the license store 38 (step 721).

It is to be understood that a user's computing device 14 may on occasion malfunction, and licenses 16 stored in the license store 38 of the DRM system 32 on such user's computing device 14 may become irretrievably lost. Accordingly, it is preferable that the license server 24 maintain a database 50 of issued licenses 16 (Fig. 1), and that such license server 24 provide a user with a  
25 copy or re-issue (hereinafter 're-issue') of an issued license 16 if the user is in fact entitled to such re-issue. In the aforementioned case where licenses 16 are irretrievably lost, it is also likely the case that state information stored in the state store 40 and corresponding to such licenses 16 is also lost. Such lost state information should be taken into account when re-issuing a license 16. For  
30 example, a fixed number of renderings license 16 might legitimately be re-issued



version number and a certificate with a digital signature from a certifying authority.

As was discussed above in connection with the license acquisition function, the version number of the black box 30 indicates the relative age and/or use thereof.

The certificate with the digital signature from the certifying authority, also

5 discussed above in connection with the license acquisition function, is a proffer or vouching mechanism from the certifying authority that a license server 24 should trust the black box 30. Of course, the license server 24 must trust the certifying authority to issue such a certificate for a black box 30 that is in fact trustworthy. It may be the case, in fact, that the license server 24 does not trust a particular

10 certifying authority, and refuses to honor any certificate issued by such certifying authority. Trust may not occur, for example, if a particular certifying authority is found to be engaging in a pattern of improperly issuing certificates.

Preferably, and as was discussed above, the black box server 26 includes a new unique public / private key pair (PU-BB, PR-BB) with the newly

15 generated unique black box 30 (step 903 of Fig. 9). Preferably, the private key for the black box 30 (PR-BB) is accessible only to such black box 30, and is hidden from and inaccessible by the remainder of the world, including the computing device 14 having the DRM system 32 with such black box 30, and the user thereof.

20 Most any hiding scheme may be employed without departing from the spirit and scope of the present invention, so long as such hiding scheme in fact performs the function of hiding the private key (PR-BB) from the world. As but one example, the private key (PR-BB) may be split into several sub-components, and each sub-component may be encrypted uniquely and stored in

25 a different location. In such a situation, it is preferable that such sub-components are never assembled in full to produce the entire private key (PR-BB).

In one embodiment of the present invention, such private key (PR-BB) is encrypted according to code-based encryption techniques. In particular, in such embodiment, the actual software code of the black box 30 (or other software

30 code) is employed as encrypting key(s). Accordingly, if the code of the black box

30 (or the other software code) becomes adulterated or otherwise modified, for example by a user with nefarious purposes, such private key (PR-BB) cannot be decrypted.

5 Although each new black box 30 is delivered with a new public / private key pair (PU-BB, PR-BB), such new black box 30 is also preferably given access to old public / private key pairs from old black boxes 30 previously delivered to the DRM system 32 on the user's computing device 14 (step 905). Accordingly, the upgraded black box 30 can still employ the old key pairs to access older digital content 12 and older corresponding licenses 16 that were  
10 generated according to such old key pairs, as will be discussed in more detail below.

Preferably, the upgraded black box 30 delivered by the black box server 26 is tightly tied to or associated with the user's computing device 14. Accordingly, the upgraded black box 30 cannot be operably transferred among  
15 multiple computing devices 14 for nefarious purposes or otherwise. In one embodiment of the present invention, as part of the request for the black box 30 (step 901) the DRM system 32 provides hardware information unique to such DRM system 32 and/or unique to the user's computing device 14 to the black box server 26, and the black box server 26 generates a black box 30 for the DRM  
20 system 32 based in part on such provided hardware information. Such generated upgraded black box 30 is then delivered to and installed in the DRM system 32 on the user's computing device 14 (steps 907, 909). If the upgraded black box 30 is then somehow transferred to another computing device 14, the transferred black box 30 recognizes that it is not intended for such other computing device 14, and  
25 does not allow any requested rendering to proceed on such other computing device 14.

Once the new black box 30 is installed in the DRM system 32, such DRM system 32 can proceed with a license acquisition function or with any other function.

## DRM SYSTEM 32 - Content Rendering, Part 3

Referring now to Fig. 5B, and assuming, now, that the license evaluator 36 has found at least one valid license 16 and that at least one of such valid licenses 16 provides the user with the rights necessary to render the

5 corresponding digital content 12 in the manner sought (i.e., is enabling), the license evaluator 36 then selects one of such licenses 16 for further use (step 519). Specifically, to render the requested digital content 12, the license evaluator 36 and the black box 30 in combination obtain the decryption key (KD) from such license 16, and the black box 30 employs such decryption key (KD) to

10 decrypt the digital content 12. In one embodiment of the present invention, and as was discussed above, the decryption key (KD) as obtained from the license 16 is encrypted with the black box 30 public key (PU-BB(KD)), and the black box 30 decrypts such encrypted decryption key with its private key (PR-BB) to produce the decryption key (KD) (steps 521, 523). However, other methods of obtaining

15 the decryption key (KD) for the digital content 12 may be employed without departing from the spirit and scope of the present invention.

Once the black box 30 has the decryption key (KD) for the digital content 12 and permission from the license evaluator 36 to render the digital content 12, control may be returned to the rendering application 34 (steps 525,

20 527). In one embodiment of the present invention, the rendering application 34 then calls the DRM system 32 / black box 30 and directs at least a portion of the encrypted digital content 12 to the black box 30 for decryption according to the decryption key (KD) (step 529). The black box 30 decrypts the digital content 12 based upon the decryption key (KD) for the digital content 12, and then the black

25 box 30 returns the decrypted digital content 12 to the rendering application 34 for actual rendering (steps 533, 535). The rendering application 34 may either send a portion of the encrypted digital content 12 or the entire digital content 12 to the black box 30 for decryption based on the decryption key (KD) for such digital content 12 without departing from the spirit and scope of the present invention.



- the digital signature from the license server 24 based on (KD (DRL)) and (PU-BB (KD)) and encrypted with the license server 24 private key (i.e., (S (PR-LS))); and

- the certificate that the license server 24 obtained previously from  
5 the content server 22 (i.e., (CERT (PU-LS) S (PR-CS))),

and also bearing in mind that the package 12p having the digital content 12, as seen in Fig. 3, includes:

- the content ID of such digital content 12;
- the digital content 12 encrypted by KD (i.e., (KD(CONTENT)));
- 10 - a license acquisition script that is not encrypted; and
- the key KD encrypting the content server 22 public key (PU-CS), signed by the content server 22 private key (PR-CS) (i.e., (KD (PU-CS) S (PR-CS))),

in one embodiment of the present invention, the specific sequence  
15 of key transactions that are performed with regard to a specific one of the licenses 16 for the digital content 12 is as follows:

1. Based on (PU-BB (KD)) from the license 16, the black box 30 of the DRM system 32 on the user's computing device 14 applies its private key (PR-BB) to obtain (KD) (step 1001). (PR-BB (PU-BB (KD)) = (KD)). Note,  
20 importantly, that the black box 30 could then proceed to employ KD to decrypt the digital content 12 without any further ado. However, and also importantly, the license server 24 trusts the black box 30 not to do so. Such trust was established at the time such license server 24 issued the license 16 based on the certificate from the certifying authority vouching for the trustworthiness of such black box 30.

25 Accordingly, despite the black box 30 obtaining the decryption key (KD) as an initial step rather than a final step, the DRM system 32 continues to perform all license 16 validation and evaluation functions, as described below.

2. Based on (KD (PU-CS) S (PR-CS)) from the digital content 12, the black box 30 applies the newly obtained decryption key (KD) to obtain  
30 (PU-CS) (step 1003). (KD (KD (PU-CS)) = (PU-CS)). Additionally, the black box



30 can apply (PU-CS) as against the signature (S (PR-CS)) to satisfy itself that such signature and such digital content 12 / package 12p is valid (step 1005). If not valid, the process is halted and access to the digital content 12 is denied.

3. Based on (CERT (PU-LS) S (PR-CS)) from the license 16,  
5 the black box 30 applies the newly obtained content server 22 public key (PU-CS) to satisfy itself that the certificate is valid (step 1007), signifying that the license server 24 that issued the license 16 had the authority from the content server 22 to do so, and then examines the certificate contents to obtain (PU-LS) (step 1009). If not valid, the process is halted and access to the digital content 12  
10 based on the license 16 is denied.

4. Based on (S (PR-LS)) from the license 16, the black box 30 applies the newly obtained license server 24 public key (PU-LS) to satisfy itself that the license 16 is valid (step 1011). If not valid, the process is halted and access to the digital content 12 based on the license 16 is denied.

15 5. Assuming all validation steps are successful, and that the DRL 48 in the license 16 is in fact encrypted with the decryption key (KD), the license evaluator 36 then applies the already-obtained decryption key (KD) to (KD(DRL)) as obtained from the license 16 to obtain the license terms from the license 16 (i.e., the DRL 48) (step 1013). Of course, if the DRL 48 in the license  
20 16 is not in fact encrypted with the decryption key (KD), step 1013 may be omitted. The license evaluator 36 then evaluates / interrogates the DRL 48 and determines whether the user's computing device 14 has the right based on the DRL 48 in the license 16 to render the corresponding digital content 12 in the manner sought (i.e., whether the DRL 48 is enabling) (step 1015). If the license  
25 evaluator 36 determines that such right does not exist, the process is halted and access to the digital content 12 based on the license 16 is denied.

6. Finally, assuming evaluation of the license 16 results in a positive determination that the user's computing device 14 has the right based on the DRL 48 terms to render the corresponding digital content 12 in the manner  
30 sought, the license evaluator 36 informs the black box 30 that such black box 30



2. the root entity returns the license server public key (PU-LS) to such license server 24 encrypted with the private root key (PR-R) (i.e., (CERT (PU-LS) S (PR-R))); and

3. the license server 24 then issues a license 16 with a signature encrypted with the license server private key (S (PR-LS)), and also attaches to the license the certificate from the root entity (CERT (PU-LS) S (PR-R)).

For a DRM system 18 to validate such issued license 16, then, the DRM system 18:

1. applies the public root key (PU-R) to the attached certificate (CERT (PU-LS) S (PR-R)) to obtain the license server public key (PU-LS); and
2. applies the obtained license server public key (PU-LS) to the signature of the license 16 (S (PR-LS)).

Importantly, it should be recognized that just as the root entity gave the license server 24 permission to issue licenses 16 by providing the certificate (CERT (PU-LS) S (PR-R)) to such license server 24, such license server 24 can provide a similar certificate to a second license server 24 (i.e., (CERT (PU-LS2) S (PR-LS1))), thereby allowing the second license server to also issue licenses 16. As should now be evident, a license 16 issued by the second license server would include a first certificate (CERT (PU-LS1) S (PR-R)) and a second certificate (CERT (PU-LS2) S (PR-LS1)). Likewise, such license 16 is validated by following the chain through the first and second certificates. Of course, additional links in the chain may be added and traversed.

One advantage of the aforementioned signature verification process is that the root entity may periodically change the private root key (PR-R), thereby likewise periodically requiring each license server 24 to obtain a new certificate (CERT (PU-LS) S (PR-R)). Importantly, as a requirement for obtaining such new certificate, each license server may be required to upgrade itself. As with the black box 30, if a license server 24 is relatively current, i.e., has been upgraded relatively recently, it is less likely that license server 24 has been successfully

00000000000000000000000000000000

attacked. Accordingly, as a matter of trust, each license server 24 is preferably required to be upgraded periodically via an appropriate upgrade trigger mechanism such as the signature verification process. Of course, other upgrade mechanisms may be employed without departing from the spirit and scope of the present invention.

Of course, if the private root key (PR-R) is changed, then the public root key (PU-R) in each DRM system 18 must also be changed. Such change may for example take place during a normal black box 30 upgrade, or in fact may require that a black box 30 upgrade take place. Although a changed public root key (PU-R) may potentially interfere with signature validation for an older license 16 issued based on an older private root key (PR-R), such interference may be minimized by requiring that an upgraded black box 30 remember all old public root keys (PU-R). Alternatively, such interference may be minimized by requiring signature verification for a license 16 only once, for example the first time such license 16 is evaluated by the license evaluator 36 of a DRM system 18. In such case, state information on whether signature verification has taken place should be compiled, and such state information should be stored in the state store 40 of the DRM system 18.

#### Digital Rights License 48

In the present invention, the license evaluator 36 evaluates a Digital Rights License (DRL) 48 as the rights description or terms of a license 16 to determine if such DRL 48 allows rendering of a corresponding piece of digital content 12 in the manner sought. In one embodiment of the present invention, the DRL 48 may be written by a licensor (i.e., the content owner) in any DRL language.

As should be understood, there are a multitude of ways to specify a DRL 48. Accordingly, a high degree of flexibility must be allowed for in any DRL language. However, it is impractical to specify all aspects of a DRL 48 in a particular license language, and it is highly unlikely that the author of such a

language can appreciate all possible licensing aspects that a particular digital licensor may desire. Moreover, a highly sophisticated license language may be unnecessary and even a hindrance for a licensor providing a relatively simple DRL 48. Nevertheless, a licensor should not be unnecessarily restricted in how to  
5 specify a DRL 48. At the same time, the license evaluator 36 should always be able to get answers from a DRL 48 regarding a number of specific license questions.

In the present invention, and referring now to Fig. 11, a DRL 48 can be specified in any license language, but includes a language identifier or tag 54.  
10 The license evaluator 36 evaluating the license 16, then, performs the preliminary step of reviewing the language tag 54 to identify such language, and then selects an appropriate license language engine 52 for accessing the license 16 in such identified language. As should be understood, such license language engine 52 must be present and accessible to the license evaluator 36. If not present, the  
15 language tag 54 and/or the DRL 48 preferably includes a location 56 (typically a web site) for obtaining such language engine 52.

Typically, the language engine 52 is in the form of an executable file or set of files that reside in a memory of the user's computing device 14, such as a hard drive. The language engine 52 assists the license evaluator 36 to directly  
20 interrogate the DRL 48, the license evaluator 36 interrogates the DRL 48 indirectly via the language engine 48 acting as an intermediary, or the like. When executed, the language engine 52 runs in a work space in a memory of the user's computing device 14, such as RAM. However, any other form of language engine 52 may be employed without departing from the spirit and scope of the present  
25 invention.

Preferably, any language engine 52 and any DRL language supports at least a number of specific license questions that the license evaluator 36 expects to be answered by any DRL 48, as will be discussed below. Accordingly, the license evaluator 36 is not tied to any particular DRL language; a  
30 DRL 48 may be written in any appropriate DRL language; and a DRL 48 specified

in a new license language can be employed by an existing license evaluator 36 by having such license evaluator 36 obtain a corresponding new language engine 52.

## 5 DRL Languages

Two examples of DRL languages, as embodied in respective DRLs 48, are provided below. The first, 'simple' DRL 48 is written in a DRL language that specifies license attributes, while the second 'script' DRL 48 is written in a DRL language that can perform functions according to the script specified in the DRL 48. While written in a DRL language, the meaning of each line of code should be apparent based on the linguistics thereof and/or on the attribute description chart that follows:

Simple DRL 48:

```

15 <LICENSE>
   <DATA>
   <NAME>Beastie Boy's Play</NAME>
   <ID>39384</ID>
   <DESCRIPTION>Play the song 3 times</DESCRIPTION>
20 <TERMS></TERMS>
   <VALIDITY>
   <NOTBEFORE>19980102 23:20:14Z</NOTBEFORE>
   <NOTAFTER>19980102 23:20:14Z</NOTAFTER>
   </VALIDITY>
25 <ISSUEDDATE>19980102 23:20:14Z</ISSUEDDATE>
   <LICENSORSITE>http://www.foo.com</LICENSORSITE>
   <CONTENT>
   <NAME>Beastie Boy's</NAME>
   <ID>392</ID>
30 <KEYID>39292</KEYID>

```



<TYPE>Person</TYPE>  
<ID>39299482010</ID>  
<NAME>Arnold Blinn</NAME>  
<AUTHTYPE>Authenticate user</AUTHTYPE>  
5 <AUTHDATA>\\redmond\arnoldb</AUTHDATA>  
</PRINCIPAL>  
</PRINCIPAL>  
<DRLTYPE>Simple</DRLTYPE>[the language tag 54]  
<DRLDATA>  
10 <START>19980102 23:20:14Z</START>  
<END>19980102 23:20:14Z</END>  
<COUNT>3</COUNT>  
<ACTION>PLAY</ACTION>  
</DRLDATA>  
15 <ENABLINGBITS>aaaabbbbccccddd</ENABLINGBITS>  
</DATA>  
<SIGNATURE>  
<SIGNERNAME>Universal</SIGNERNAME>  
<SIGNERID>9382ABK3939DKD</SIGNERID>  
20 <HASHALGORITHMID>MD5</HASHALGORITHMID>  
<SIGNALGORITHMID>RSA 128</SIGNALGORITHMID>  
<SIGNATURE>xxxxxxxxyyyyxxxxyy</SIGNATURE>  
<SIGNERPUBKEY></SIGNERPUBKEY>  
<CONTENTSSIGNEDSIGNERPUBKEY></CONTENTSSIGNEDSIGNERPUB  
25 KEY>  
</SIGNATURE>  
</LICENSE>  
  
Script DRL 48:  
30 <LICENSE>



<DATA>  
<NAME>Beastie Boy's Play</NAME>  
<ID>39384</ID>  
<DESCRIPTION>Play the song unlimited</DESCRIPTION>  
5 <TERMS></TERMS>  
<VALIDITY>  
<NOTBEFORE>19980102 23:20:14Z</NOTBEFORE>  
<NOTAFTER>19980102 23:20:14Z</NOTAFTER>  
</VALIDITY>  
10 <ISSUEDDATE>19980102 23:20:14Z</ISSUEDDATE>  
<LICENSORSITE>http://www.foo.com</LICENSORSITE>  
<CONTENT>  
<NAME>Beastie Boy's</NAME>  
<ID>392</ID>  
15 <KEYID>39292</KEYID>  
<TYPE>MS Encrypted ASF 2.0</TTYPE>  
</CONTENT>  
<OWNER>  
<ID>939KDKD393KD</ID>  
20 <NAME>Universal</NAME>  
<PUBLICKEY></PUBLICKEY>  
</OWNER>  
<LICENSEE>  
<NAME>Arnold</NAME>  
25 <ID>939KDKD393KD</ID>  
<PUBLICKEY></PUBLICKEY>  
</LICENSEE>  
<DRLTYPE>Script</DRLTYPE>[the language tag 54]  
<DRLDATA>  
30 function on\_enable(action, args) as boolean

```
result = False
```

```
if action = "PLAY" then
```

```
  result = True
```

```
end if
```

```
5 on_action = False
```

```
end function
```

```
...
```

```
</DRLDATA>
```

```
</DATA>
```

```
10 <SIGNATURE>
```

```
<SIGNERNAME>Universal</SIGNERNAME>
```

```
<SIGNERID>9382</SIGNERID>
```

```
<SIGNERPUBLICKEY></SIGNERPUBLICKEY>
```

```
<HASHID>MD5</HASHID>
```

```
15 <SIGNID>RSA 128</SIGNID>
```

```
<SIGNATURE>xxxxxxxxyyyyxxxxyyy</SIGNATURE>
```

```
<CONTENTSIGNEDSIGNERPUBLICKEY></CONTENTSIGNEDSIGNERPUBLIC  
KEY>
```

```
</SIGNATURE>
```

```
20 </LICENSE>
```

In the two DRLs 48 specified above, the attributes listed have the following descriptions and data types:

Attribute	Description	Data Type
Id	ID of the license	GUID
Name	Name of the license	String
Content Id	ID of the content	GUID
Content Key Id	ID for the encryption key of the content	GUID
Content Name	Name of the content	String
Content Type	Type of the content	String
Owner Id	ID of the owner of the content	GUID

Owner Name	Name of the owner of the content	String
Owner Public Key	Public key for owner of content. This is a base-64 encoded public key for the owner of the content.	String
Licensee Id	Id of the person getting license. It may be null.	GUID
Licensee Name	Name of the person getting license. It may be null.	String
Licensee Public Key	Public key of the licensee. This is the base-64 encoded public key of the licensee. It may be null.	String
Description	Simple human readable description of the license	String
Terms	Legal terms of the license. This may be a pointer to a web page containing legal prose.	String
Validity Not After	Validity period of license expiration	Date
Validity Not Before	Validity period of license start	Date
Issued Date	Date the license was issued	Date
DRL Type	Type of the DRL. Example include ASIMPLE@ or ASCRIP@	String
DRL Data	Data specific to the DRL	String
Enabling Bits	These are the bits that enable access to the actual content. The interpretation of these bits is up to the application, but typically this will be the private key for decryption of the content. This data will be base-64 encoded. Note that these bits are encrypted using the	String

	public key of the individual machine.	
Signer Id	ID of person signing license	GUID
Signer Name	Name of person signing license	String
Signer Public Key	Public key for person signing license. This is the base-64 encode public key for the signer.	String
Content Signed Signer Public Key	Public key for person signing the license that has been signed by the content server private key. The public key to verify this signature will be encrypted in the content. This is base-64 encoded.	String
Hash Alg Id	Algorithm used to generate hash. This is a string, such as AMD5@.	String
Signature Alg Id	Algorithm used to generate signature. This is a string, such as ARSA 128@.	String
Signature	Signature of the data. This is base-64 encoded data.	String

#### Methods

As was discussed above, it is preferable that any language engine 52 and any DRL language support at least a number of specific license questions 5 that the digital license evaluator 36 expects to be answered by any DRL 48. Recognizing such supported questions may include any questions without departing from the spirit and scope of the present invention, and consistent with the terminology employed in the two DRL 48 examples above, in one embodiment of the present invention, such supported questions or 'methods' include 'access 10 methods', 'DRL methods', and 'enabling use methods', as follows:

#### Access Methods

Access methods are used to query a DRL 48 for top-level attributes.

#### 5 VARIANT QueryAttribute (BSTR key)

Valid keys include License.Name, License.Id, Content.Name, Content.Id, Content.Type, Owner.Name, Owner.Id, Owner.PublicKey, Licensee.Name, Licensee.Id, Licensee.PublicKey, Description, and Terms, each  
10 returning a BSTR variant; and Issued, Validity.Start and Validity.End, each returning a Date Variant.

#### DRL Methods

The implementation of the following DRL methods varies from DRL  
15 48 to DRL 48. Many of the DRL methods contain a variant parameter labeled 'data' which is intended for communicating more advanced information with a DRL 48. It is present largely for future expandability.

#### Boolean IsActivated(Variant data)

20 This method returns a Boolean indicating whether the DRL 48 / license 16 is activated. An example of an activated license 16 is a limited operation license 16 that upon first play is active for only 48 hours.

#### 25 Activate(Variant data)

This method is used to activate a license 16. Once a license 16 is activated, it cannot be deactivated.

#### 30 Variant QueryDRL(Variant data)

This method is used to communicate with a more advanced DRL 48. It is largely about future expandability of the DRL 48 feature set.

5 Variant GetExpires(BSTR action, Variant data)

This method returns the expiration date of a license 16 with regard to the passed-in action. If the return value is NULL, the license 16 is assumed to never expire or does not yet have an expiration date because it hasn't been  
10 activated, or the like.

Variant GetCount(BSTR action, Variant data)

This method returns the number of operations of the passed-in  
15 action that are left. If NULL is returned, the operation can be performed an unlimited number of times.

Boolean IsEnabled(BSTR action, Variant data)

20 This method indicates whether the license 16 supports the requested action at the present time.

Boolean IsSunk(BSTR action, Variant data)

This method indicates whether the license 16 has been paid for. A  
25 license 16 that is paid for up front would return TRUE, while a license 16 that is not paid for up front, such as a license 16 that collects payments as it is used, would return FALSE.

Enabling Use Methods.

These methods are employed to enable a license 16 for use in decrypting content.

#### Boolean Validate (BSTR key)

5

This method is used to validate a license 16. The passed-in key is the black box 30 public key (PU-BB) encrypted by the decryption key (KD) for the corresponding digital content 12 (i.e., (KD(PU-BB))) for use in validation of the signature of the license 16. A return value of TRUE indicates that the license 16 is valid. A return value of FALSE indicates invalid.

10

#### int OpenLicense 16(BSTR action, BSTR key, Variant data)

This method is used to get ready to access the decrypted enabling bits. The passed-in key is (KD(PU-BB)) as described above. A return value of 0 indicates success. Other return values can be defined.

15

#### BSTR GetDecryptedEnablingBits (BSTR action, Variant data)

#### Variant GetDecryptedEnablingBitsAsBinary (BSTR action, Variant

20 Data)

These methods are used to access the enabling bits in decrypted form. If this is not successful for any of a number of reasons, a null string or null variant is returned.

25

#### void CloseLicense 16 (BSTR action, Variant data)

This method is used to unlock access to the enabling bits for performing the passed-in action. If this is not successful for any of a number of reasons, a null string is returned.

30

## Heuristics

As was discussed above, if multiple licenses 16 are present for the same piece of digital content 12, one of the licenses 16 must be chosen for further use. Using the above methods, the following heuristics could be implemented to make such choice. In particular, to perform an action (say APLAY@) on a piece of digital content 12, the following steps could be performed:

- 10           1.     Get all licenses 16 that apply to the particular piece of digital content 12.
2.     Eliminate each license 16 that does not enable the action by calling the IsEnabled function on such license 16.
3.     Eliminate each license 16 that is not active by calling IsActivated on such license 16.
- 15           4.     Eliminate each license 16 that is not paid for up front by calling IsSunk on such license 16.
5.     If any license 16 is left, use it. Use an unlimited-number-of-plays license 16 before using a limited-number-of-plays license 16, especially if the unlimited-number-of-plays license 16 has an expiration date. At any time, the user should be allowed to select a specific license 16 that has already been acquired, even if the choice is not cost-effective. Accordingly, the user can select a license 16 based on criteria that are perhaps not apparent to the DRM system
- 20           32.
6.     If there are no licenses 16 left, return status so indicating.
- 25     The user would then be given the option of:
  - using a license 16 that is not paid for up front, if available;
  - activating a license 16, if available; and/or
  - performing license acquisition from a license server 24.



## RETAIL TRANSACTION

As is to be appreciated, there are a multitude of scenarios in which a customer may obtain a piece of digital content 12 and also obtain a corresponding yet separate digital license 16. For one example, the customer may visit a retailer and upon payment of a fee thereto obtain the aforementioned content 12 and the license 16 from a licensor. For another example, the customer may obtain the content 12 as originally distributed by way of a retailer or as re-distributed from an intermediary, and then visit a licensor and upon payment of a fee thereto obtain the license 16. While it is envisioned that either of the aforementioned scenarios is implemented by way of an inter-communicating network of computers such as the Internet, and specifically by appropriately configured Internet web sites or the like and Internet web pages or the like, it is to be understood that other implementing communicative assemblages and devices may be employed without departing from the spirit and scope of the present invention.

As used herein, a retailer is any sales agent operating a sales site for 'selling' the content 12, whether or not the retailer actually operates a content server 22, whether or not the retailer actually obtains a payment in exchange for a license 16, whether or not the retailer actually obtains a payment separately and apart from the license 16 for the content 12 itself, and whether or not the retailer actually distributes the content 12 or directs the customer to another site for distribution of the content 12. As used herein, a licensor is any licensing agent that operates a licensing site for granting a license 16, whether or not the licensor actually obtains a payment in exchange for a license 16.

In any case, the party collecting the payment (i.e., the retailer or the licensor) likely is expected to share the proceeds with the other party (i.e., the licensor or the retailer). Also, if the obtained content 12 is re-distributed to another individual (a friend of the customer, e.g.), and the individual obtains its own license 16 by way of payment to the retailer or the licensor, the retailer and licensor likely wish to share the proceeds from that payment, too. Moreover, if the same originally obtained content 12 is re-distributed several times, the retailer and

licensor may wish to share the proceeds from payments for corresponding licenses 16 in a manner dependent on the number of licenses 16 issued in connection with the originally obtained content 12. In such a situation, then, a mechanism is necessary whereby a license count is maintained with regard to the originally obtained content 12. Also, in the case where the retailer collects payment, a mechanism is necessary whereby the licensor is assured that such payment is in fact collected prior to issuing the license 16.

#### RETAIL TRANSACTION – PAYING THE LICENSOR / LICENSE SERVER 24

In one scenario, and in one embodiment of the present invention, a customer obtains content 12 either as distributed directly from a retailer or as re-distributed by way of one or more intermediaries and thus indirectly from a retailer. Thereafter, such customer obtains the corresponding yet separate license 16 from a licensor operating a license server 24, where the licensor collects a payment from the customer in exchange for the obtained license 16.

Here, the licensor likely is expected to share the payment with the retailer, both in the situation where the content 12 is distributed and re-distributed. Accordingly, the retailer needs to be able to identify itself to the licensor in order to collect from such licensor its shared portion of the payment. In addition, the retailer and licensor may wish to share the payments for multiple licenses 16 based on the same originally distributed content in a manner dependent on the number of such licenses 16. Accordingly, a license count is maintained by the licensor with regard to the originally distributed content 12.

In one embodiment of the present invention, then, and referring now to Fig. 13, the present scenario is implemented in three aspects: at the content server 22, at the retailer 60, and at the license server 24. Briefly, the content 12 is produced in the form of a package 12p by the content server 22 to include an area for containing retailer and customer identification information; the retailer 60 either controls the content server 22 to define the retailer and customer identification information or receives the package 12p and adds such retailer and

008260" 4972960

5

10

15

20

25

30

customer identification information, and then distributes the content 12 to a customer; and the license server 24 receives a license request for a corresponding license 16 which includes the retailer and customer identification information. Thus, the license server 24 can identify the retailer 60 and customer and can properly credit the retailer 60 for a portion of the payment received by the license server 24 for the license 16. Each aspect will be discussed in turn.

As was discussed above in connection with Fig. 3, the content package 12p as issued by the content server 22 includes the content 12 and license acquisition information for acquiring a corresponding license 16. Here, such license acquisition information includes a site identifier such as a URL for an Internet web site or the like at which the license server 24 may be accessed. Importantly, and referring now to Fig. 14, the URL in the package 12p as issued includes an ItemID field or the like at the end of the URL, where the ItemID field is null (i.e., initially empty or filled with dummy data to act as a spacer) (step 1401):

`www.LicenseServer.com/issuelicense?ItemID=xxxxxxxxxxxx`

Of course, the URL with the ItemID field may take any appropriate form without departing from the spirit and scope of the present invention. As should be appreciated, the ItemID field is not used by the content server 22 but instead is set aside for later use by the retailer 60, as will be discussed below. The package 12p with the content 12 and the URL with the ItemID field is thus delivered to the retailer 60 by way of any appropriate delivery channel (step 1403). In an alternative, the retailer 60 controls the content server 22, and therefore can immediately populate the ItemID field in the manner set forth below (step 1405).

The retailer 60 holds the content 12 and distributes such content 12 to a customer 62 upon request therefrom. Importantly, in the present context, the retailer distributes the content 12 / package 12p to the customer 62 without collecting any license fees therefrom. That is, while the retailer 60 may choose to collect a payment from the customer in exchange for distributing the package 12p

thereto, such payment is more in the nature of a download or transaction fee, and not a fee for a corresponding license 16. As seen below, such a license fee is in fact collected by a license server 24 in the present context. As may be appreciated, the mechanisms employed to distribute the content 12 / package 12p to the customer 62 may be any particular mechanisms without departing from the spirit and scope of the present invention. For example, the package 12p may be downloaded from a file transfer server or the like. Such mechanisms are known or should be apparent to the relevant public and therefore need not be described herein in any detail.

Importantly, in the present context, prior to distributing the package 12p having the content 12 to the customer 62 (step 1409), the retailer modifies the ItemID field in the URL for the license server 24 to include:

- a customer package ID (cpID) unique to the customer 62 and to the particular package 12p as delivered to such customer 62, where such cpID identifies the content as originally distributed from the retailer 60; and
- a retailer ID (retailerID) unique to the retailer 60:

`www.LicenseServer.com/issuelicense?ItemID=[cpID, retailerID, etc.]`

(step 1407). In addition, the retailer 60 may add other information without departing from the spirit and scope of the present invention. For example, such other information may include an identification of the customer, a time stamp, and/or a digital signature. At least a portion of the modified ItemID field may be in an encrypted form to prevent tampering. Alternatively, the digital signature may be based at least in part on a portion of the modified ItemID field so that changes to such modified ItemID field, either innocent or nefarious, will cause the digital signature to fail to verify.

Notably, inclusion of the retailer ID and perhaps other information from the retailer 60 allows the retailer to indelibly mark the package 12p having

the content 12 with information identifying the retailer 60. Thus, no matter how many times the package 12p is re-distributed ('super-distributed'), the information identifying the retailer 60 remains with the package 12p. Accordingly, the origin of the package 12p and its progeny (i.e., the super-distributed copies of the package 12p) may always be determined. More importantly, and as will be seen below, the retailer 60 may be credited with not only the first sale of a license 16 for the package 12p, but also for all subsequent sales of licenses 16 for the package 12p and its progeny.

To recap, then, the package 12p as distributed to the customer 62 includes a customer package ID and a retailer ID as written in the ItemID field by the retailer 60. In addition, the package 12p includes a content ID identifying the content, as is seen in Fig. 3. Thus, when the customer 62 receives the package 12p and then issues a license request to a license server 24 as defined by the URL (step 1411), such license request includes the customer package ID and the retailer ID as part of the URL, and includes the content ID, as was discussed above in connection with Fig. 7.

The license server 24 upon receiving such license request and related information proceeds with the license issuance process in the manner described above in connection with Fig. 7. Importantly, in the present context, the license server 24 issues a license 16 in exchange for a license fee payment 64 (Fig. 13) from the customer 62 (step 1413), which as was discussed above is to be shared in some pre-determined manner with the retailer 60. As may be appreciated, the mechanisms employed to receive the payment 64 from the customer 62 may be any particular mechanisms without departing from the spirit and scope of the present invention. For example, the payment 64 may be by way of a credit / debit / charge card number. Moreover, the payment 64 may be non-monetary in nature, such as for example a barter chit, an earned credit, or a promise to perform a function in the future. Such mechanisms are known or should be apparent to the relevant public and therefore need not be described herein in any detail.

In one embodiment of the present invention, and specifically in the present context, the license server 24 de-constructs the ItemID field of the URL to obtain the customer package ID and the retailer ID, and also obtains the content ID (step 1415). Thus, the license server 24 knows the unique customer package  
5 12p for which a license 16 is sought, the retailer 60 that sold the package 12p and that is owed at least a portion of the collected payment 64, and the content 12 that was in the package 12p. The license server 24 then proceeds to a database 66 and records such information therein for accounting and fee distribution purposes.

10 Specifically, and as seen in Fig. 12, the database 66 includes an entry for each content ID, and each content ID entry includes a sub-entry for each customer package ID and retailer ID combination related to the content ID. In addition, each sub-entry includes a count for counting the number of times a license 16 has been issued for a specific content ID – customer package ID –  
15 retailer ID combination. Of course, the database 66 may be organized in other ways without departing from the spirit and scope of the present invention.

Thus, the license server 24 finds the content ID entry in the database 66, or creates one if none is present (step 1417), finds the customer package ID – retailer ID sub-entry under such content ID entry, or creates one if  
20 none is present (step 1419), and increments the count in such sub-entry (step 1421). Accordingly, each time a license 16 is issued for a specific content ID – customer package ID – retailer ID combination, the associated count thereof is incremented. While the customer 62 presumably requests a single license 16 for the content 12, it must be remembered that the customer 62 may re-distribute the  
25 package 12p having the content 12 to one or more other customers 62a (Fig. 13), and each other customer 62a will require a license 16 from the license server 24 based on the same specific content ID – customer package ID – retailer ID combination in exchange for a payment 64 to such license server 24. Thus, the associated count for such combination can easily become significant.

Importantly, by knowing the retailer ID, content ID, and customer package ID associated with a license request, the license server 24 / licensor knows that it 'owes' the retailer 60 associated with such retailer ID at least a portion of the payment 64 previously received by such license server 24 (step

5 1413) in connection with issuing a license 16 for such content ID and customer package ID. Accordingly, at an appropriate time and in an appropriate manner, the payment 64 is in fact shared with the retailer 60 (step 1423).

Correspondingly, if for some reason a license request came to the license server 24 without a retailer ID, the license server 24 / licensor would not know which

10 retailer 60 it owes in connection therewith. In such a situation, the license server 24 would likely refuse to issue such a license 16, or perhaps only issue a relatively restrictive license 16.

All of this of course assumes that the license server 24 / licensor and the retailer have defined a business relationship wherein the portion of the

15 payment 64 is in fact owed. Alternatively, it may be the case wherein no payment 64 is owed in the defined business relationship. Nevertheless, the license server 24 / licensor can reliably determine from the retailer ID where the original copy of the package 12p was obtained.

Also importantly, with the count associated with each specific

20 content ID – customer package ID – retailer ID combination, such license server 24 / licensor can determine how the payment 64 is to be shared with the retailer 60, especially if the retailer 60 and licensor have already agreed to share the payments 64 for multiple licenses 16 based on the same originally distributed content 12 in a manner dependent on the number of such licenses 16.

In one embodiment of the present invention, the Item ID includes

25 customer ID information identifying the customer that purchased the original package 12p. Thus, all progeny of the package 12p also identify the customer. Accordingly, the customer may be 'credited' for each license 16 obtained in connection with the package 12p and its progeny. Such customer credit may be





embodiment of the present invention, and as seen in Fig. 15, the retailer 60 identifies itself to the license server 24 by interposing itself between the customer 62 and the license server 24.

In particular, in one embodiment of the present invention, and specifically in the present context, the customer 62 visits the retailer 60, perhaps by way of a web site or the like, selects a piece of digital content 12 for purchasing, and forwards to the retailer the appropriate payment 64 (step 1601 of Fig. 16). As should be appreciated, the payment 64 represents the license fee, and perhaps other fees, and is to be shared with the license server in a pre-determined manner.

Importantly, in the present context, the retailer does not initially deliver a content package 12p having the content 12 to the customer 62. Instead, in connection with receiving the payment 64 from the customer 62, the retailer 60 delivers to the customer 62 a null or dummy package 12p having no substantial content 12, but with license acquisition information (Fig. 3) containing a URL or the like for a site controlled by the retailer 60 (step 1603). Thus, and as will be explained in more detail below, a 'dummy' license request based on the dummy package 12p will go to the retailer 60 and not to the license server 24. The dummy package 12p may also have other information without departing from the spirit and scope of the present invention.

Along with delivering the dummy package 12p, the retailer 60 also directs the customer to a site controlled by the retailer 60 and having a controller 68 that can control the DRM system 32 of the computing device 14 of the customer 62 (step 1605). Of course, this presumes that the customer 62 is accessing the retailer 60 and its sites by way of the computing device 14, and that the DRM system 32 is present on such computing device 14. In one embodiment of the present invention, the controller 68 is downloaded to the computing device 14 of the customer 62 as part of a page such as an HTML web page, although such controller 68 may be downloaded in other forms without departing from the spirit and scope of the present invention. Controlling aspects of a computing

device 14 by way of a controller 68 at a site is known or should be apparent to the relevant public, and accordingly is not discussed herein in any detail.

In the present context, the controller 68 directs the DRM system 32 of the computing device 14 of the customer 62 to send a license request for a  
5 license 16 for the dummy package 12p (step 1607). The controller 68 may initiate the sending of the license request by direct command, or may initiate such sending of such license request by commanding that the dummy package 12p be played. As should be appreciated, the play command initiates a license search in the license store 38 (Fig. 4), followed by a failure to locate any corresponding  
10 license 16, followed by an automatic license request based on the license acquisition information in the dummy package 12p. Preferably, the controller 68 performs / initiates such actions automatically and without any prompting on the part of the customer 62, such that the procedure appears to be transparent or seamless to such customer 62. Of course, the customer 62 really desires a  
15 license 16 for the purchased content 12, not to mention the content 12 itself, but as will be seen below both items will in fact be delivered to such customer 62 based on the license request associated with the dummy package 12p.

As was discussed above, the license acquisition information in the dummy package 12p contains a URL or the like for a site controlled by the retailer  
20 60. Thus, the aforementioned license request goes to the retailer 60 rather than the license server (step 1609). As may be appreciated, such action is necessary so that the retailer 60 can add certain information to the license request before forwarding same to the license server 24, where such added information identifies the retailer 60 to the license server 24 and acknowledges to the license server 24  
25 that such retailer 60 owes a portion of the received payment 64.

Note that such information may instead be placed in the dummy package 12p prior to delivering such dummy package 12p to the customer 62 (step 1603). However, since such added information acts as the aforementioned acknowledgement, it is generally better not to include such added information until  
30 necessary. Otherwise, a nefarious entity may somehow obtain and employ the

added information / acknowledgment and use it to obtain a license in the manner set forth below, even though the retailer 60 never collected any corresponding payment 64. Note, too, that the actual package 12p of the content 12 may initially be delivered to the customer. However, such delivery may take a substantial amount of time during which the retailer 60 is waiting to complete the transaction (collecting payment 64, adding the information, passing the license request off (see below)). Preferably, the transaction is completed relatively quickly, thus delivery of the actual package 12p is delayed until after the transaction is complete.

10           As should be recalled, the license request includes information from the computing device 14 of the customer 62 such as the public key of the black box 30 of the DRM system 32 (PU-BB) or another customer secret, among other things. Here, the retailer modifies the license request to retain such customer-based information, and to add retailer-based information, including but not limited to a retailer ID identifying the retailer, and a secret that proves to the license server 24 that the retailer 60 actually authorized issuance of a license 16 (step 1611). As should be appreciated, based on the added retailer-based information, the retailer 60 is in effect agreeing that it owes to the licensor / license server 24 a portion of the payment 64 received in connection with the transaction.

20           Of course, other information may be added / modified without departing from the spirit and scope of the present invention. For one example, the license request includes a content ID which may or may not be for the actual purchased content 12. If so, the content ID is left alone. If not, the content ID is modified to be for such actual purchased content 12. Of course, the retailer knows the correct content ID for the actual purchased content 12 based on the activities that occurred in connection with the selection and purchase thereof, as discussed above in connection with step 1601. Moreover, the modified license request may be organized into any appropriate form without departing from the spirit and scope of the present invention, as long as such form is amenable to the license server 24.

25

30

Once the license request had been appropriately modified by the retailer 60, such retailer forwards such modified license request to the licensor / license server 24 (step 1613). Typically, the modified request is forwarded to a site identified by a site identifier such as a URL where such site is controlled by / run by the licensor / license server 24, although other identifying indicia may be employed without departing from the spirit and scope of the present invention.

At this point, the license server 24 has received the modified license request, and thus has information including: (1) the content ID for content 12 for which a license 16 has been requested; and (2) the public key of the black box 30 of the DRM system 32 (PU-BB) of the customer 62 or another customer secret, among other things. Thus, the license server 24 can prepare and issue a license 16 to the customer 62 based on the content ID and the PU-BB or other customer secret (step 1615). In the present context of the present invention, the license 16 is prepared and issued by the license server 24 in a manner such as that which was outlined above. However, other methods of license preparation may be employed without departing from the spirit and scope of the present invention.

In addition, based on the received modified license request, the license server 24 has information including: (3) the retailer ID identifying the retailer that collected a license fee payment 64, that authorized issuance of the requested license 16, and that owes the licensor / license server 24 at least a portion of the collected payment 64, among other things. Thus, and importantly, the license server 24 / licensor can also note that the retailer 60 identified by the retailer ID owes the licensor / license server 24 at least a portion of the collected payment 64 (step 1617). In the present context of the present invention, the license server 24 / licensor may note such debt in any appropriate manner without departing from the spirit and scope of the present invention. For one example, the license server 24 / licensor may simply keep a running count in a database (not shown). For another example, the license server 24 / licensor may maintain a database similar to if not identical with the database 66 discussed above. Thus, a count may be made based on the number of times the retailer 60 collects a

license fee for particular content 12, or for particular content 12 as originally distributed to the customer 62, for example.

The license 16 as issued by the license server 24 is received by the customer 62 and appropriately stored in the license store 38 (Fig. 4) of the DRM  
5 system 32 of such customer 62 (step 1619). Such reception and storage may be performed in the manner set forth above or in any other appropriate manner without departing from the spirit and scope of the present invention.

Of course, the customer 62 still does not have the actual package 12p with the content 12 that is the basis of the transaction. Accordingly, in one  
10 embodiment of the present context of the present invention, the controller 68 that was previously downloaded to the computing device 14 obtains such actual package 12p with the content 12 (step 1621). Such controller 68 may do so after sensing that the license 16 has been received and stored, or may do so after being directed by the license server 24, retailer 60, or another element to act after  
15 the license 16 has been received and stored. Of course, the controller 68 may take such action at other times and in response to other events without departing from the spirit and scope of the present invention.

Preferably, the controller 68 obtains the actual package 12p with the content 12 from a site identified by a site identifier, where such site identifier is  
20 provided to the controller 68. Such site identifier may be provided to the controller 68 by the license server 24, retailer 60, or another element, or the controller 68 may be downloaded to the computing device 14 with such site identifier attached thereto. Such site identifier may identify a content server 22, a site controlled by the license server 24, or another site without departing from the spirit and scope  
25 of the present invention. Preferably, the controller 68 performs / initiates such actions automatically and without any prompting on the part of the customer 62, such that the procedure appears to be transparent or seamless to such customer 62.

Now that the customer 62 has made payment 64 for the license 16,  
30 obtained the license 16, and obtained the corresponding content 12, such



In another action, the license acquisition information includes the site identifier for the retailer 60 (or another retailer 60). Again, the individual 62a may at a minimum make a license fee payment 64 to the retailer 60 and thereby initiate the series of events set forth in Fig. 16 that result in a license 16 being  
5 issued by the license server 24 to the individual 62a for the content 12. In this case, the site identifier may identify a site of the retailer 60 specifically geared to service license requests based on re-distributed content 12.

In yet another action, the license acquisition information includes the site identifier for a general help page. Such help page may contain any kind of  
10 help information without departing from the spirit and scope of the present invention. For example, such help information may list one or more retailers 60 through which a license 16 may be requested, general information on how the license acquisition process works, etc.

In connection with any of the aforementioned actions, it is to be  
15 remembered that the individual 62a already has the actual content 12. Accordingly, such content 12 need not be delivered to such individual 62a, as in step 1621. Of course, such delivery may still take place without departing from the spirit and scope of the present invention.

As heretofore disclosed, in the present context the retailer employs  
20 a dummy package 12p and a controller 68 to trigger a 'dummy' license request from a customer 62 to such retailer 60 and thereby obtain customer information. Such customer information is necessary for the retailer 60 to make an actual license request from the retailer to a license server 24, where the actual license request includes the customer information and necessary retailer ID information  
25 among other thing. In an alternate embodiment of the present context of the present invention, the retailer 60 obtains the necessary customer information by direct request from the retailer 60 to the DRM system 32 of the customer 62 step 1625). Thus, the dummy package 12p is not necessary in such alternate embodiment. The controller 68 may be employed to effectuate the obtaining of  
30 the customer information by the retailer 60, or another device may be employed

without departing from the spirit and scope of the present invention. In either embodiment, it is noted that the retailer 60 interposes itself between the customer 62 and the license server 24 to result in a license request to a license server 24 that includes both customer information and retailer ID information among other things.

#### CONCLUSION

The programming necessary to effectuate the processes performed in connection with the present invention is relatively straight-forward and should be apparent to the relevant programming public. Accordingly, such programming is not attached hereto. Any particular programming, then, may be employed to effectuate the present invention without departing from the spirit and scope thereof.

In the foregoing description, it can be seen that the present invention comprises a new and useful enforcement architecture 10 that allows the controlled rendering or playing of arbitrary forms of digital content 12, where such control is flexible and definable by the content owner of such digital content 12. Also, the present invention comprises a new useful controlled rendering environment that renders digital content 12 only as specified by the content owner, even though the digital content 12 is to be rendered on a computing device 14 which is not under the control of the content owner. Further, the present invention comprises a trusted component that enforces the rights of the content owner on such computing device 14 in connection with a piece of digital content 12, even against attempts by the user of such computing device 14 to access such digital content 12 in ways not permitted by the content owner.

It should be appreciated that changes could be made to the embodiments described above without departing from the inventive concepts thereof. It should be understood, therefore, that this invention is not limited to the particular embodiments disclosed, but it is intended to cover modifications within the spirit and scope of the present invention as defined by the appended claims.





3. The method of claim 2 wherein crediting the identified retailer comprises crediting the retailer according to the count in the entry.

5 4. The method of claim 1 comprising:  
receiving a license request for the license from the customer,  
the request including retailer information associated with the corresponding piece  
of digital content and identifying the retailer, and a content identification identifying  
the content, the method further comprising:  
retrieving the content identification from the license request  
10 and identifying the content therefrom;  
the method comprising crediting the identified retailer for a portion of the payment  
received according to the identified content.

15 5. The method of claim 4 further comprising recording the  
retailer information and content identification in a database for accounting and  
payment distribution purposes, the database including an entry for each content  
identification, each content identification entry including a sub-entry for each  
retailer information related to such content identification, each sub-entry including  
a count for counting the number of times a license has been issued for the  
20 specific content identification – retailer information combination, such recording  
comprising:

finding the content identification entry in the database  
corresponding to the content identification of the request, or creating such entry if  
none is present;

25 finding, under such content identification entry, the retailer  
information sub-entry in the database corresponding to the retailer information of  
the request, or creating such sub-entry if none is present; and  
incrementing the count in such sub-entry.

6. The method of claim 5 wherein crediting the identified retailer comprises crediting the retailer according to the count in the sub-entry.

7. The method of claim 4 comprising:

5 receiving a license request for the license from the customer, the request including retailer information associated with the corresponding piece of digital content and identifying the retailer, a content identification identifying the content, and content distribution information associated with the corresponding piece of digital content and uniquely identifying the content as distributed by the  
10 retailer, the method further comprising:

retrieving the content distribution information from the license request and identifying the content as distributed by the retailer therefrom; the method comprising crediting the identified retailer for a portion of the payment received according to the identified content and identified content as distributed  
15 by the retailer.

8. The method of claim 7 further comprising recording the retailer information, content identification, and content distribution information in a database for accounting and payment distribution purposes, the database  
20 including an entry for each content identification, each content identification entry including a sub-entry for each customer distribution information and retailer information combination related to such content identification, each sub-entry including a count for counting the number of times a license has been issued for the specific content identification – customer distribution information – retailer  
25 information combination, such recording comprising:

finding the content identification entry in the database corresponding to the content identification of the request, or creating such entry if none is present;

finding, under such content identification entry, the customer  
30 distribution information – retailer information sub-entry in the database

corresponding to the customer distribution information – retailer information of the request, or creating such sub-entry if none is present; and  
incrementing the count in such sub-entry.

5                   9.     The method of claim 8 wherein crediting the identified retailer comprises crediting the retailer according to the count in the sub-entry.

10                   10.    The method of claim 7 wherein receiving the license request comprises receiving the license request as addressed to a site identified by a site identifier, the site identifier including the content distribution information attached thereto, and wherein retrieving the content distribution information comprises retrieving the content distribution information as attached to the site identifier.

15                   11.    The method of claim 1 further comprising issuing the license.

                    12.    The method of claim 1 wherein receiving the license request comprises receiving the license request as addressed to a site identified by a site identifier, the site identifier including the retailer information attached thereto, and wherein retrieving the retailer information comprises retrieving the retailer  
20 information as attached to the site identifier.

                    13.    A method of distributing digital content from a retailer to a customer, the method comprising:  
                        retrieving the content as issued by a content provider, the as  
25 issued content having license acquisition information for acquiring a corresponding license attached thereto, the license acquisition information including a site identifier identifying a site at which the customer may obtain a digital license corresponding to the content, the site identifier in the license acquisition information attached to the as issued content including an additional  
30 information field attached thereto;

modifying such additional information field to include retailer information identifying the retailer; and

delivering the content with the modified additional information field to the customer,

5 whereby a license request sent from the customer is addressed to the site identified by the site identifier in the license acquisition information and includes the modified additional information field attached thereto.

10 14. The method of claim 13 wherein modifying such additional information field comprises modifying such additional information field to include content distribution information uniquely identifying the content as distributed by the retailer.

15 15. The method of claim 13 wherein modifying such additional information field comprises modifying such additional information field to include a digital signature based at least in part on a portion of the modified additional information field.

20 16. The method of claim 13 wherein the retailer is the content provider.

17. The method of claim 13 wherein the retailer distributes the content to the customer without collecting any license fee therefrom.

25 18. A computer-readable medium having computer-executable instructions thereon for issuing a digital license to a customer for a corresponding piece of digital content, the content originating from a retailer, the instructions comprising modules including:

00360" 57972960

a first module for receiving a license request for the license from the customer, the request including retailer information associated with the corresponding piece of digital content and identifying the retailer;

5 a second module for receiving a payment from the customer in connection with license request;

a third module for retrieving the retailer information from the license request and identifying the retailer therefrom; and

a fourth module for crediting the identified retailer for a portion of the payment received.

10

19. The medium of claim 18 wherein the fourth module records the retailer information in a database for accounting and payment distribution purposes, the database including an entry for each retailer information, each entry including a count for counting the number of times a license has been issued for the specific retailer information combination, the fourth module including:

15

a first sub-module for finding the retailer information entry in the database corresponding to the retailer information of the request, or creating such sub-entry if none is present; and

20

a second sub-module for incrementing the count in such entry.

20. The medium of claim 19 wherein the fourth module credits the retailer according to the count in the entry.

25

21. The medium of claim 18 comprising:

the first module for receiving a license request for the license from the customer, the request including retailer information associated with the corresponding piece of digital content and identifying the retailer, and a content identification identifying the content, the medium further comprising:

a fifth module for retrieving the content identification from the license request and identifying the content therefrom;  
the fourth module crediting the identified retailer for a portion of the payment received according to the identified content.

5

22. The medium of claim 21 wherein the fourth module records the retailer information and content identification in a database for accounting and payment distribution purposes, the database including an entry for each content identification, each content identification entry including a sub-entry for each  
10 retailer information related to such content identification, each sub-entry including a count for counting the number of times a license has been issued for the specific content identification – retailer information combination, the fourth module including:

a first sub-module for finding the content identification entry in  
15 the database corresponding to the content identification of the request, or creating such entry if none is present;

a second sub-module for finding, under such content identification entry, the retailer information sub-entry in the database corresponding to the retailer information of the request, or creating such sub-entry  
20 if none is present; and

a third sub-module for incrementing the count in such sub-entry.

23. The medium of claim 22 wherein the fourth module credits  
25 the retailer according to the count in the sub-entry.

24. The medium of claim 21 comprising:  
the first module for receiving a license request for the license from the customer, the request including retailer information associated with the  
30 corresponding piece of digital content and identifying the retailer, a content









a third module retrieving the retailer information from the license request and identifying the retailer therefrom; and

a fourth module crediting the identified retailer for a portion of the payment received.

5

36. The computer of claim 35 wherein the fourth module records the retailer information in a database for accounting and payment distribution purposes, the database including an entry for each retailer information, each entry including a count for counting the number of times a license has been issued for the specific retailer information combination, the fourth module including:

10

a first sub-module finding the retailer information entry in the database corresponding to the retailer information of the request, or creating such sub-entry if none is present; and

15

a second sub-module incrementing the count in such entry.

37. The computer of claim 36 wherein the fourth module credits the retailer according to the count in the entry.

20

38. The computer of claim 35 comprising:

the first module receiving a license request for the license from the customer, the request including retailer information associated with the corresponding piece of digital content and identifying the retailer, and a content identification identifying the content, the medium further comprising:

25

a fifth module retrieving the content identification from the license request and identifying the content therefrom; the fourth module crediting the identified retailer for a portion of the payment received according to the identified content.

30

39. The computer of claim 38 wherein the fourth module records the retailer information and content identification in a database for accounting and

payment distribution purposes, the database including an entry for each content identification, each content identification entry including a sub-entry for each retailer information related to such content identification, each sub-entry including a count for counting the number of times a license has been issued for the  
5 specific content identification – retailer information combination, the fourth module including:

a first sub-module finding the content identification entry in the database corresponding to the content identification of the request, or creating such entry if none is present;

10                   a second sub-module finding, under such content identification entry, the retailer information sub-entry in the database corresponding to the retailer information of the request, or creating such sub-entry if none is present; and

a third sub-module incrementing the count in such sub-entry.

15

40. The computer of claim 39 wherein the fourth module credits the retailer according to the count in the sub-entry.

41. The computer of claim 38 comprising:

20

the first module receiving a license request for the license from the customer, the request including retailer information associated with the corresponding piece of digital content and identifying the retailer, a content identification identifying the content, and content distribution information associated with the corresponding piece of digital content and uniquely identifying  
25 the content as distributed by the retailer, the medium further comprising:

a fifth module retrieving the content distribution information from the license request and identifying the content as distributed by the retailer therefrom;

the fourth module crediting the identified retailer for a portion of the payment received according to the identified content and identified content as distributed by the retailer.

5                    42.    The computer of claim 41 wherein the fourth module records the retailer information, content identification, and content distribution information in a database for accounting and payment distribution purposes, the database including an entry for each content identification, each content identification entry including a sub-entry for each customer distribution information and retailer  
10 information combination related to such content identification, each sub-entry including a count for counting the number of times a license has been issued for the specific content identification – customer distribution information – retailer information combination, the fourth module including:

   a first sub-module finding the content identification entry in  
15 the database corresponding to the content identification of the request, or creating such entry if none is present;

   a second sub-module finding, under such content  
identification entry, the customer distribution information – retailer information  
sub-entry in the database corresponding to the customer distribution information –  
20 retailer information of the request, or creating such sub-entry if none is present;  
and

   a third module incrementing the count in such sub-entry.

                                 43.    The computer of claim 42 wherein the fourth module credits  
25 the retailer according to the count in the sub-entry.

                                 44.    The computer of claim 41 wherein the first module receives the license request as addressed to a site identified by a site identifier, the site identifier including the content distribution information attached thereto, and

008200" 049FZ960

wherein the fifth module retrieves the content distribution information as attached to the site identifier.

5 45. The computer of claim 35 further comprising a fifth module  
issuing the license.

10 46. The computer of claim 35 wherein the first module receives  
as addressed to a site identified by a site identifier, the site identifier including the  
retailer information attached thereto, and wherein the third module retrieves as  
attached to the site identifier.

15 47. A computer having computer-executable instructions thereon  
for distributing digital content from a retailer to a customer, the instructions  
comprising modules including:  
15 a first module retrieving the content as issued by a content  
provider, the as issued content having license acquisition information for acquiring  
a corresponding license attached thereto, the license acquisition information  
including a site identifier identifying a site at which the customer may obtain a  
digital license corresponding to the content, the site identifier in the license  
20 acquisition information attached to the as issued content including an additional  
information field attached thereto;

a second module modifying such additional information field  
to include retailer information identifying the retailer; and

25 a third module delivering the content with the modified  
additional information field to the customer,  
whereby a license request sent from the customer is addressed to the site  
identified by the site identifier in the license acquisition information and includes  
the modified additional information field attached thereto.



including a count for counting the number of times a license has been issued for the specific retailer information combination, such recording comprising:

- 5 finding the retailer information entry in the database  
corresponding to the retailer information of the request, or creating such sub-entry  
if none is present; and  
incrementing the count in such entry.

10 54. The method of claim 53 wherein crediting the identified retailer comprises crediting the retailer according to the count in the entry.

15 55. The method of claim 52 comprising:  
receiving a license request for the license from the customer,  
the request including retailer information associated with the corresponding piece  
of digital content and identifying the retailer, and a content identification identifying  
the content, the method further comprising:  
20 retrieving the content identification from the license request  
and identifying the content therefrom;  
the method comprising crediting the identified retailer according to the identified  
content.

25 56. The method of claim 55 further comprising recording the retailer information and content identification in a database for accounting purposes, the database including an entry for each content identification, each content identification entry including a sub-entry for each retailer information  
30 related to such content identification, each sub-entry including a count for counting the number of times a license has been issued for the specific content identification – retailer information combination, such recording comprising:  
finding the content identification entry in the database  
corresponding to the content identification of the request, or creating such entry if  
none is present;



finding, under such content identification entry, the retailer information sub-entry in the database corresponding to the retailer information of the request, or creating such sub-entry if none is present; and  
incrementing the count in such sub-entry.

5

57. The method of claim 56 wherein crediting the identified retailer comprises crediting the retailer according to the count in the sub-entry.

58. The method of claim 55 comprising:

10

receiving a license request for the license from the customer, the request including retailer information associated with the corresponding piece of digital content and identifying the retailer, a content identification identifying the content, and content distribution information associated with the corresponding piece of digital content and uniquely identifying the content as distributed by the retailer, the method further comprising:

15

retrieving the content distribution information from the license request and identifying the content as distributed by the retailer therefrom; the method comprising crediting the identified retailer according to the identified content and identified content as distributed by the retailer.

20

59. The method of claim 58 further comprising recording the retailer information, content identification, and content distribution information in a database for accounting purposes, the database including an entry for each content identification, each content identification entry including a sub-entry for each customer distribution information and retailer information combination related to such content identification, each sub-entry including a count for counting the number of times a license has been issued for the specific content identification – customer distribution information – retailer information combination, such recording comprising:

25





68. The method of claim 67 wherein crediting the identified originating customer comprises crediting the originating customer according to the count in the entry.

5           69. The method of claim 66 comprising:  
            receiving a license request for the license from the requesting  
customer, the request including originating customer information associated with  
the corresponding piece of digital content and identifying the originating customer,  
and a content identification identifying the content, the method further comprising:  
10           retrieving the content identification from the license request  
and identifying the content therefrom;  
the method comprising crediting the identified originating customer according to  
the identified content.

15           70. The method of claim 69 further comprising recording the  
originating customer information and content identification in a database for  
accounting purposes, the database including an entry for each content  
identification, each content identification entry including a sub-entry for each  
originating customer information related to such content identification, each sub-  
20   entry including a count for counting the number of times a license has been  
issued for the specific content identification – originating customer information  
combination, such recording comprising:  
            finding the content identification entry in the database  
corresponding to the content identification of the request, or creating such entry if  
25   none is present;  
            finding, under such content identification entry, the originating  
customer information sub-entry in the database corresponding to the originating  
customer information of the request, or creating such sub-entry if none is present;  
and  
30           incrementing the count in such sub-entry.

71. The method of claim 70 wherein crediting the identified originating customer comprises crediting the originating customer according to the count in the sub-entry.

5

72. The method of claim 69 comprising:

receiving a license request for the license from the requesting customer, the request including originating customer information associated with the corresponding piece of digital content and identifying the originating customer, a content identification identifying the content, and content distribution information associated with the corresponding piece of digital content and uniquely identifying the content as distributed by the originating customer, the method further comprising:

10

retrieving the content distribution information from the license request and identifying the content as distributed by the originating customer therefrom;

15

the method comprising crediting the identified originating customer according to the identified content and identified content as distributed by the originating customer.

20

73. The method of claim 72 further comprising recording the originating customer information, content identification, and content distribution information in a database for accounting purposes, the database including an entry for each content identification, each content identification entry including a sub-entry for each customer distribution information and originating customer information combination related to such content identification, each sub-entry including a count for counting the number of times a license has been issued for the specific content identification – customer distribution information – originating customer information combination, such recording comprising:

25

finding the content identification entry in the database corresponding to the content identification of the request, or creating such entry if none is present;

5 finding, under such content identification entry, the customer distribution information – originating customer information sub-entry in the database corresponding to the customer distribution information – originating customer information of the request, or creating such sub-entry if none is present; and

10 incrementing the count in such sub-entry.

74. The method of claim 73 wherein crediting the identified originating customer comprises crediting the originating customer according to the count in the sub-entry.

15 75. The method of claim 72 wherein receiving the license request comprises receiving the license request as addressed to a site identified by a site identifier, the site identifier including the content distribution information attached thereto, and wherein retrieving the content distribution information comprises retrieving the content distribution information as attached to the site identifier.

20 76. The method of claim 66 further comprising issuing the license.

25 77. The method of claim 66 wherein receiving the license request comprises receiving the license request as addressed to a site identified by a site identifier, the site identifier including the originating customer information attached thereto, and wherein retrieving the originating customer information comprises retrieving the originating customer information as attached to the site identifier.

78. The method of claim 66 wherein the payment comprises a non-monetary payment.

5 79. The method of claim 78 wherein the payment is selected from a group consisting of earned credits, barter chits, a promise to perform a function, and combinations thereof.

10 80. The method of claim 66 wherein the requesting customer is the originating customer.

81. The method of claim 66 wherein the requesting customer is not the originating customer.

00000"049F2460

### Abstract of the Invention

5

To distribute digital content from a retailer to a customer, the content as issued by a content provider is retrieved. The as issued content has license acquisition information for acquiring a corresponding license attached thereto, where the license acquisition information includes a site identifier identifying a site  
 10 at which the customer may obtain a digital license corresponding to the content. The site identifier includes an additional information field attached thereto. The additional information field is modified to include retailer information identifying the retailer, and the content is delivered with the modified additional information field to the customer. Thus, a license request sent from the customer is addressed to  
 15 the site identified by the site identifier in the license acquisition information and includes the modified additional information field attached thereto. The corresponding digital license is issued to the customer after receiving the license request at the site identified by the site identifier, and after payment is received at such site from the customer in connection with the license request. The retailer  
 20 information from the license request is retrieved and the retailer is identified therefrom, and such identified retailer is credited for a portion of the payment received.

25



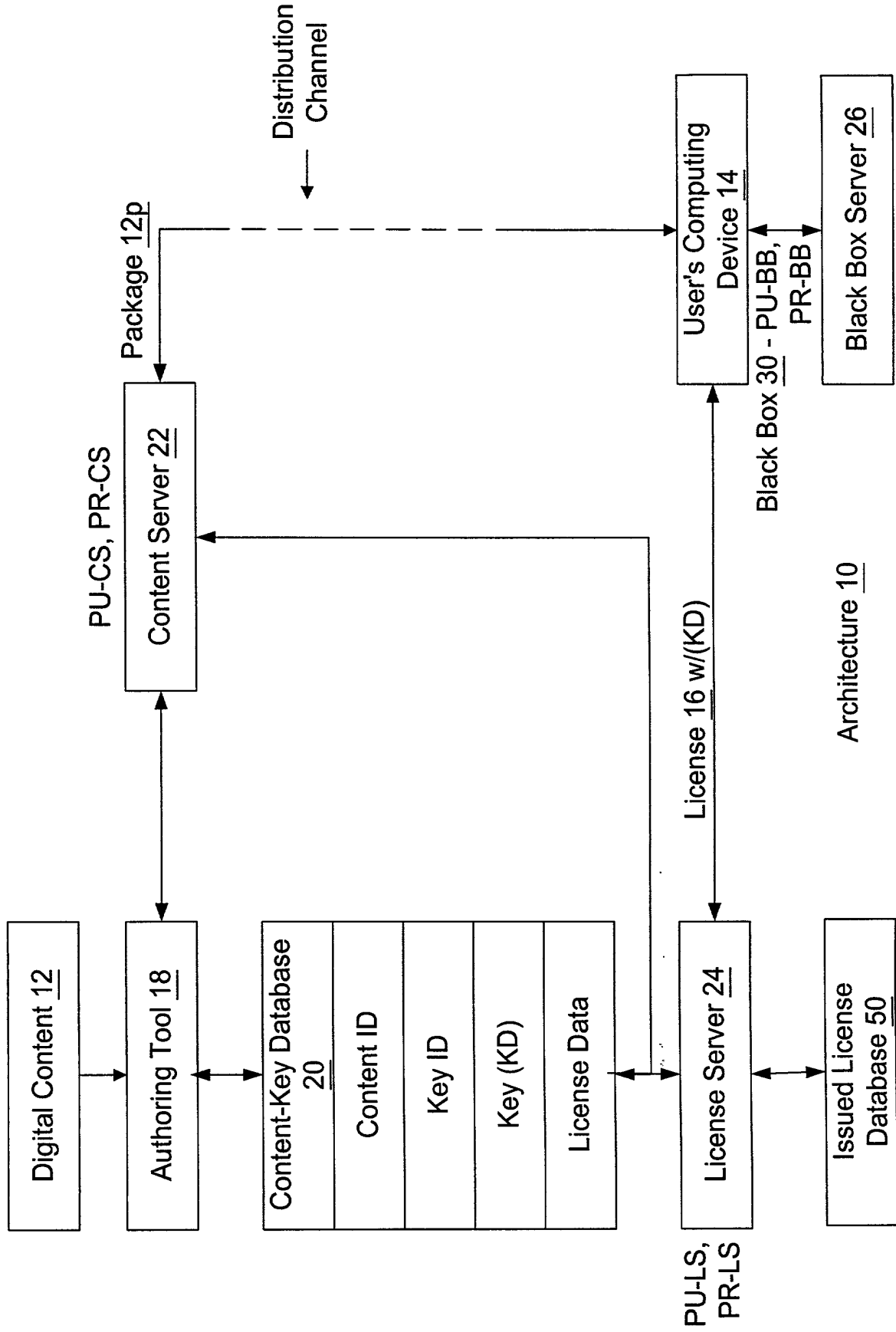

Architecture 10

Fig. 1

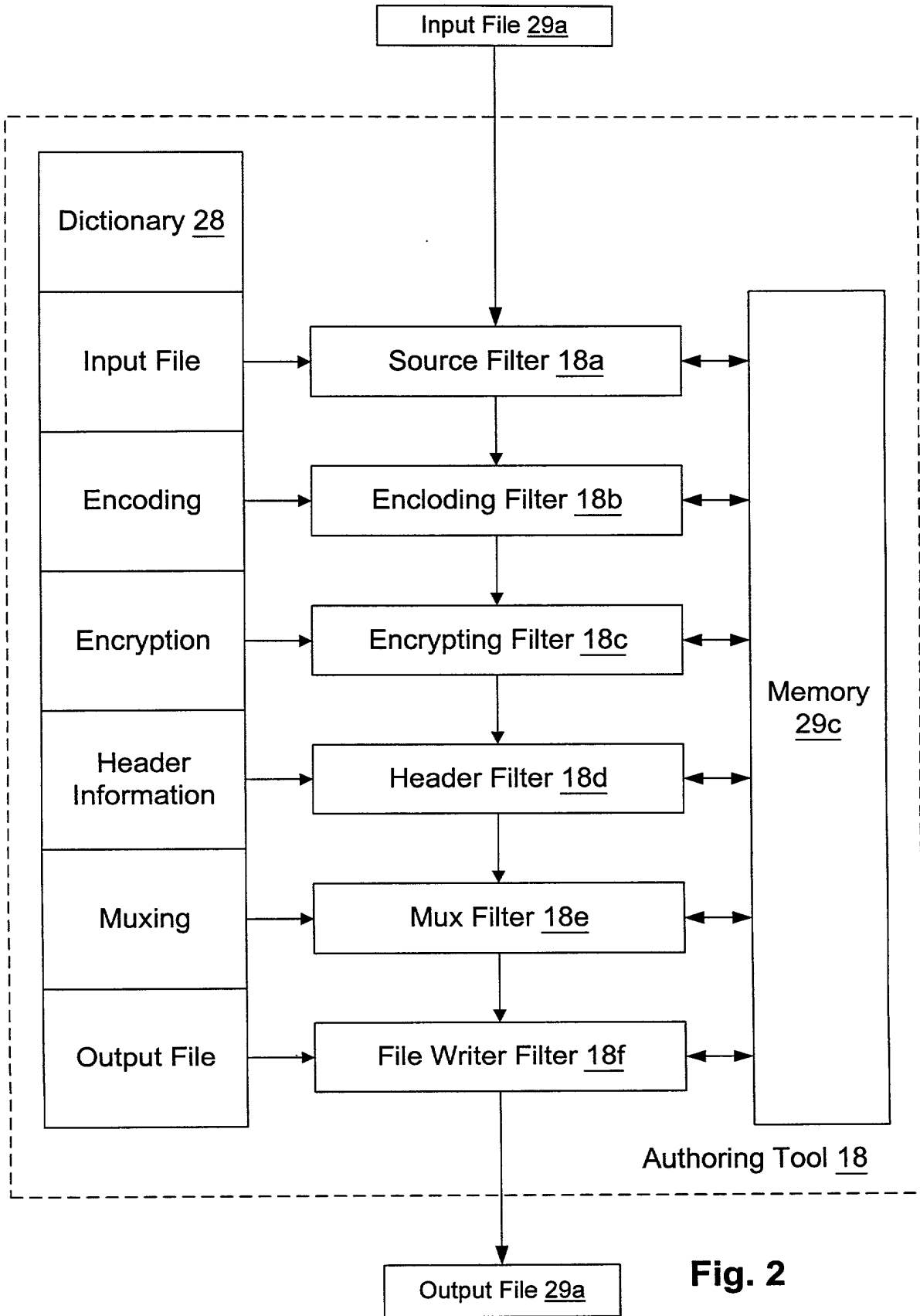

Fig. 2

Digital Content Package <u>12p</u>
KD (Digital Content <u>12</u> )
Content ID
Key ID
License Acquisition Info
KD (PU-CS) S (PR-CS)

**Fig. 3**

License <u>16</u>
Content ID
DRL <u>48</u> or KD (DRL <u>48</u> )
PU-BB (KD)
S (PR-LS)
CERT (PU-LS) S (PR-CS)

**Fig. 8**

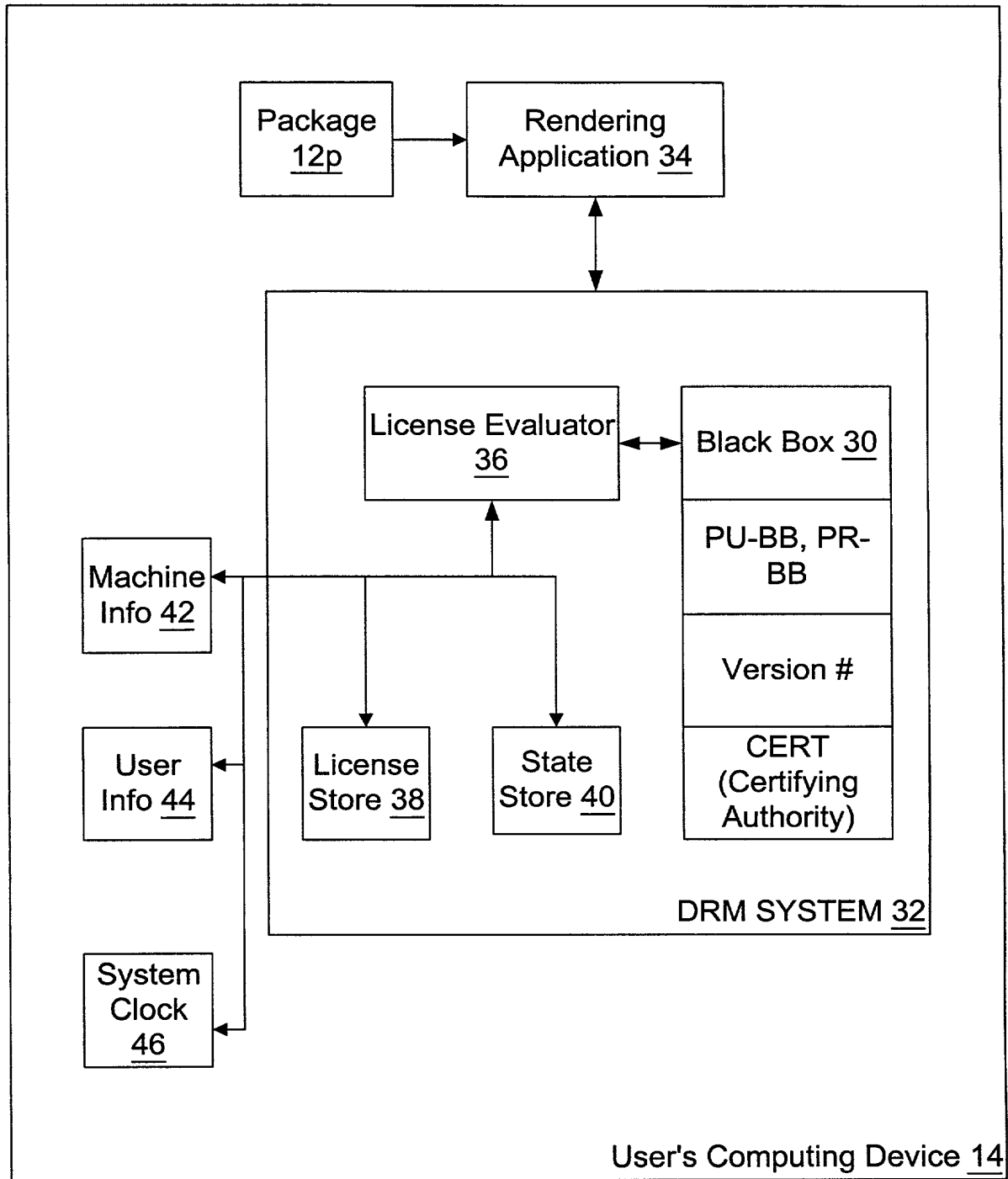
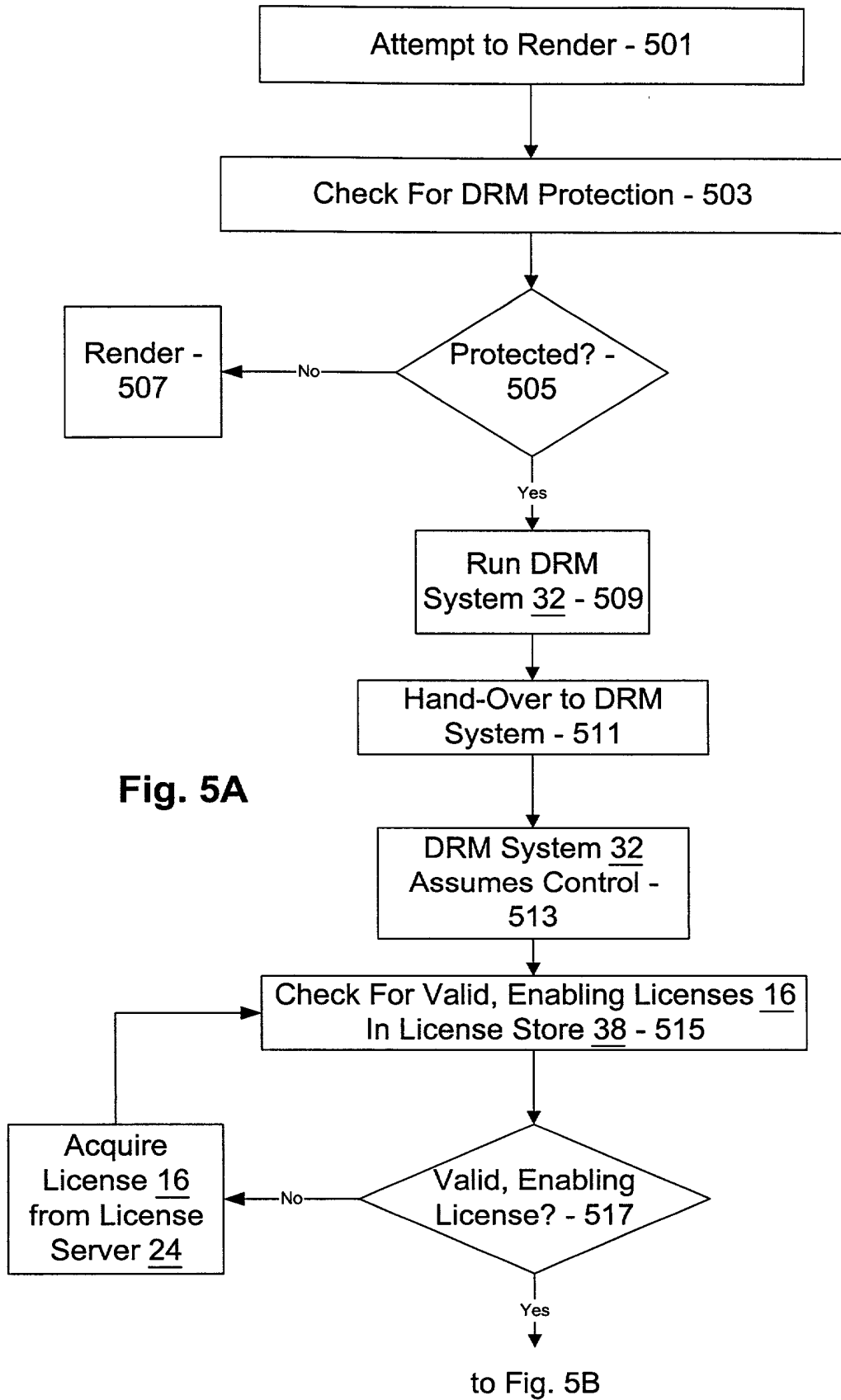

Fig. 4

00860" estfz960



**Fig. 5A**

000000 000000 000000

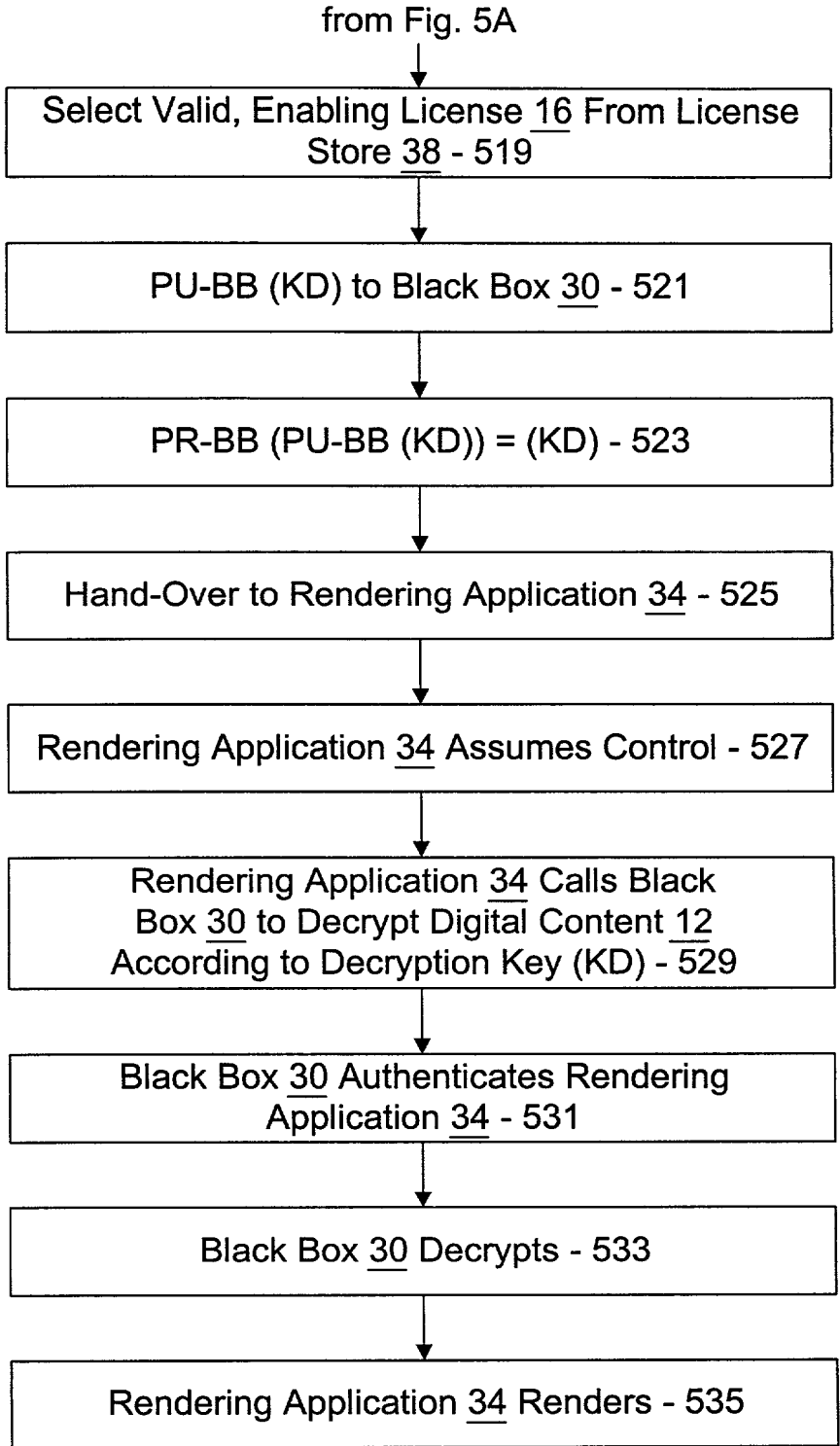

**Fig. 5B**

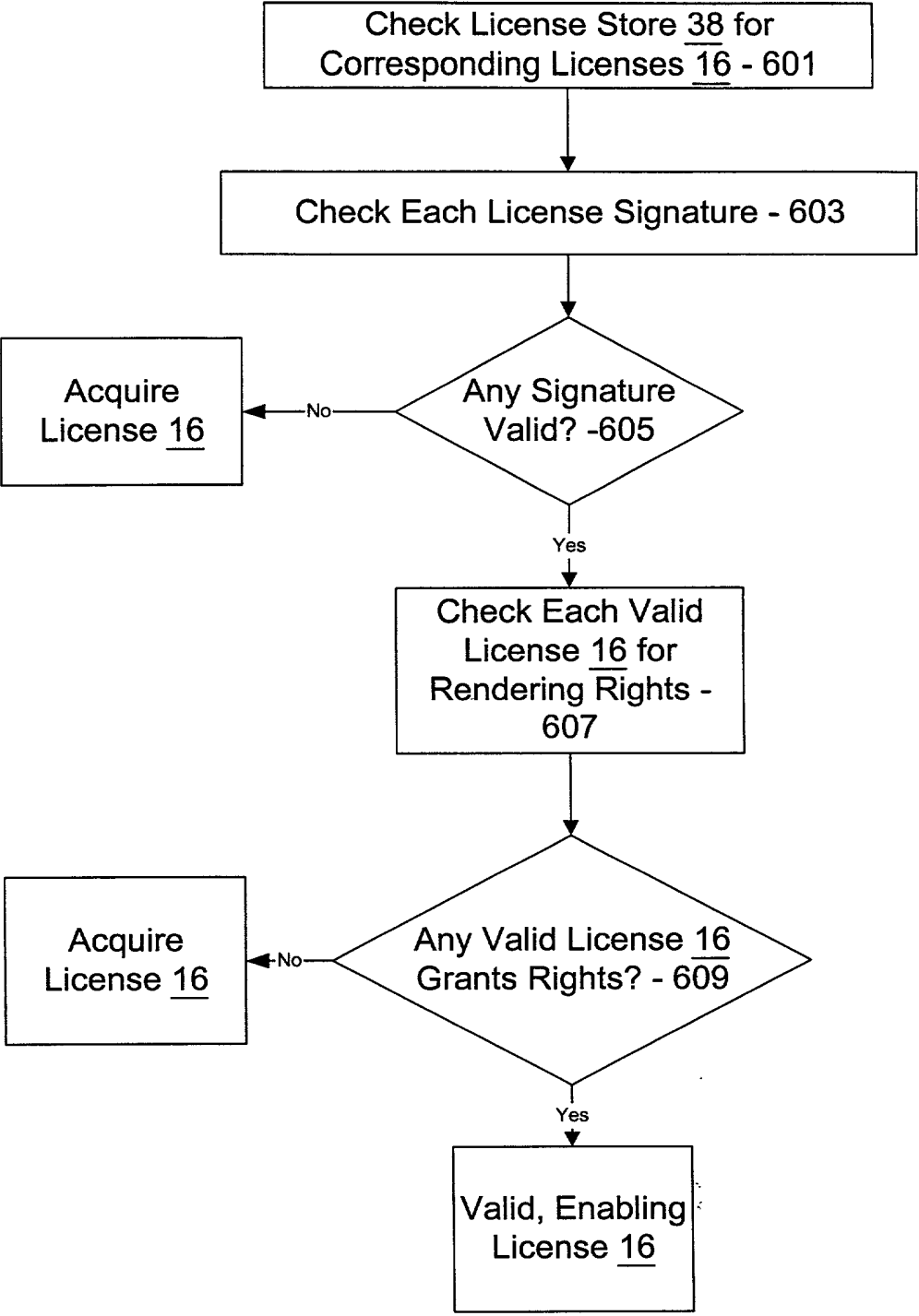

Fig. 6

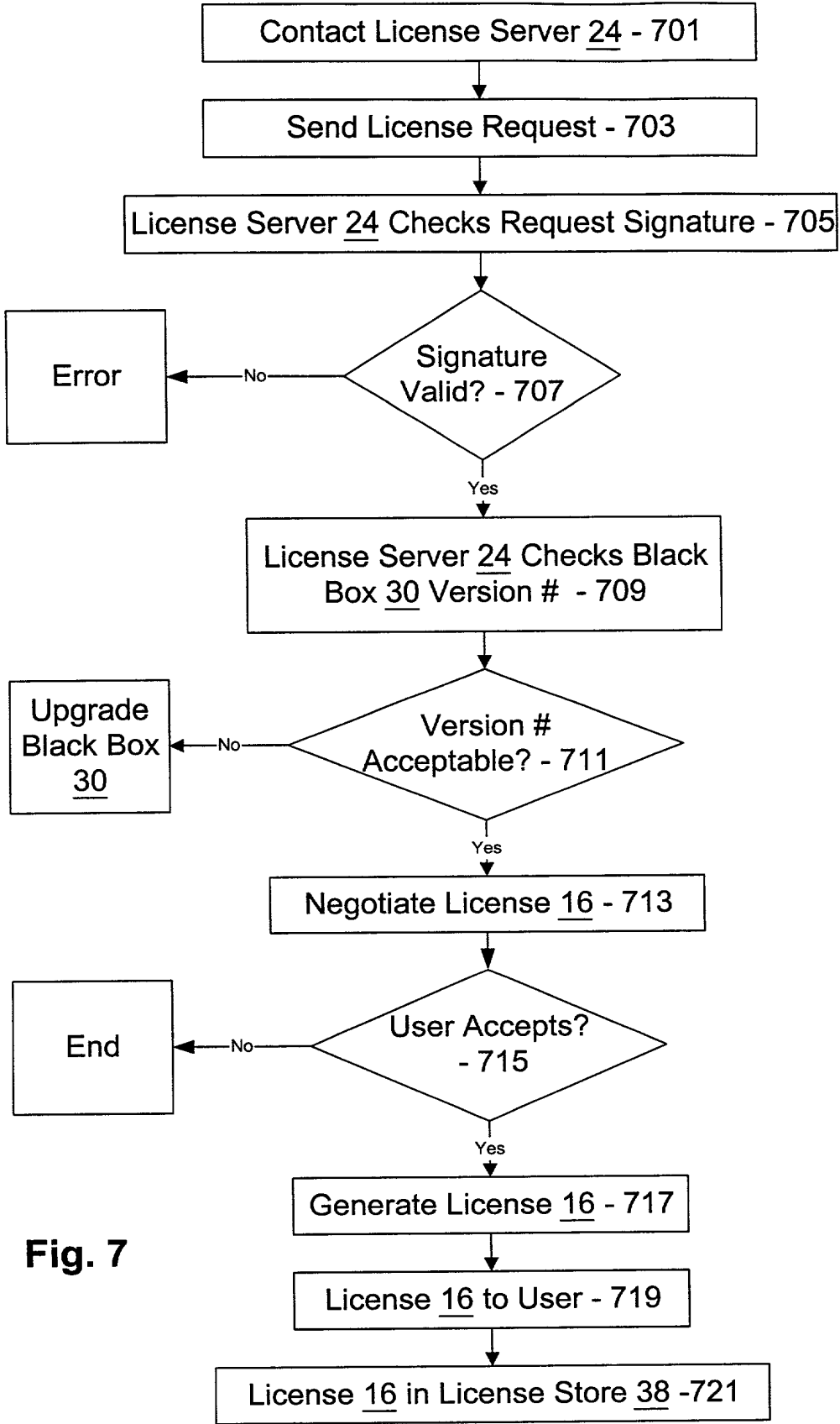
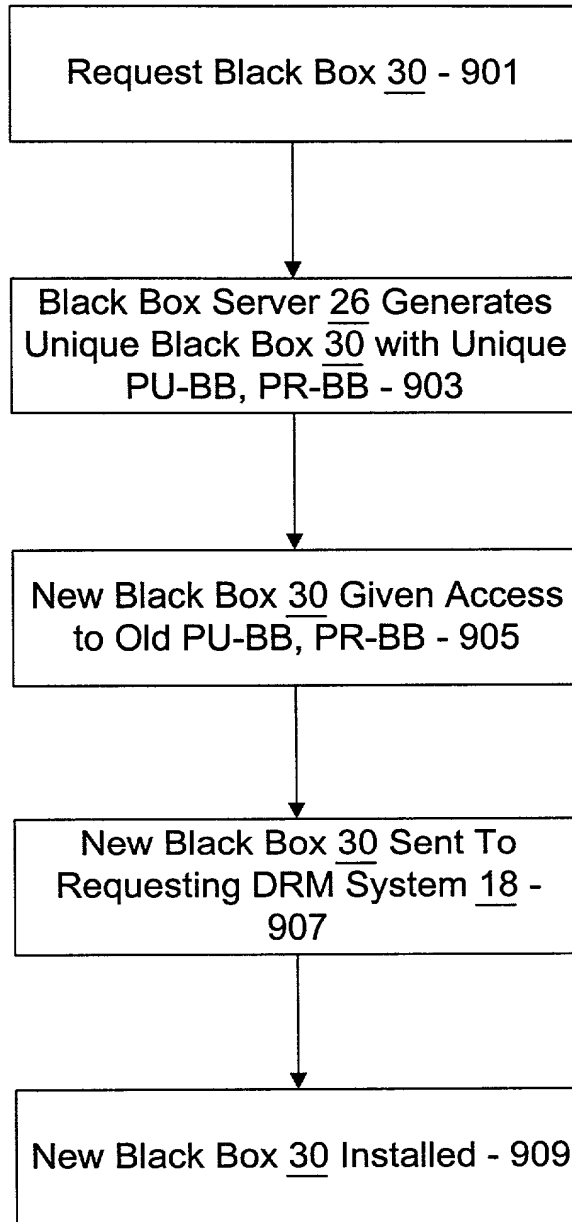

Fig. 7





**Fig. 9**

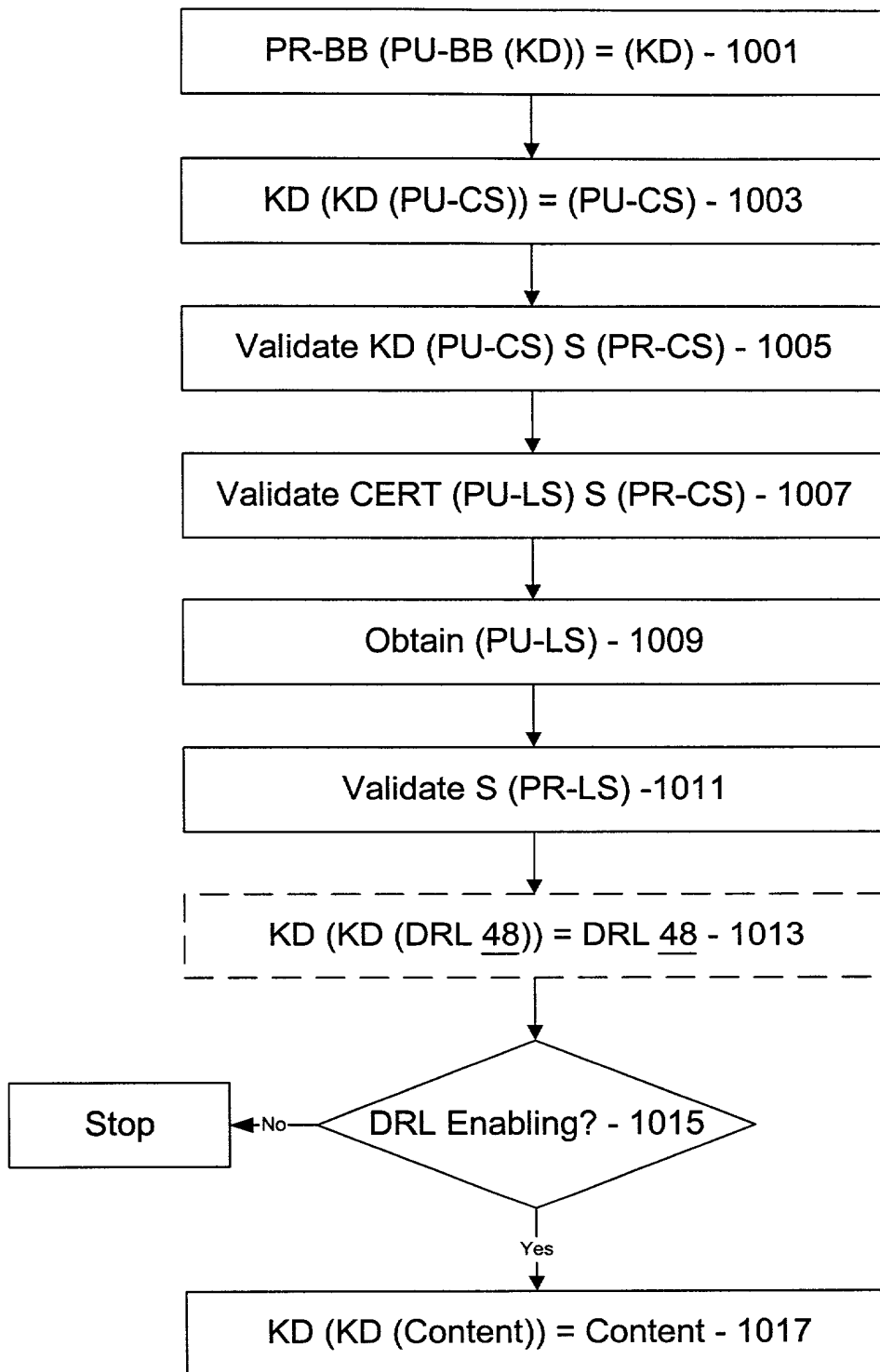
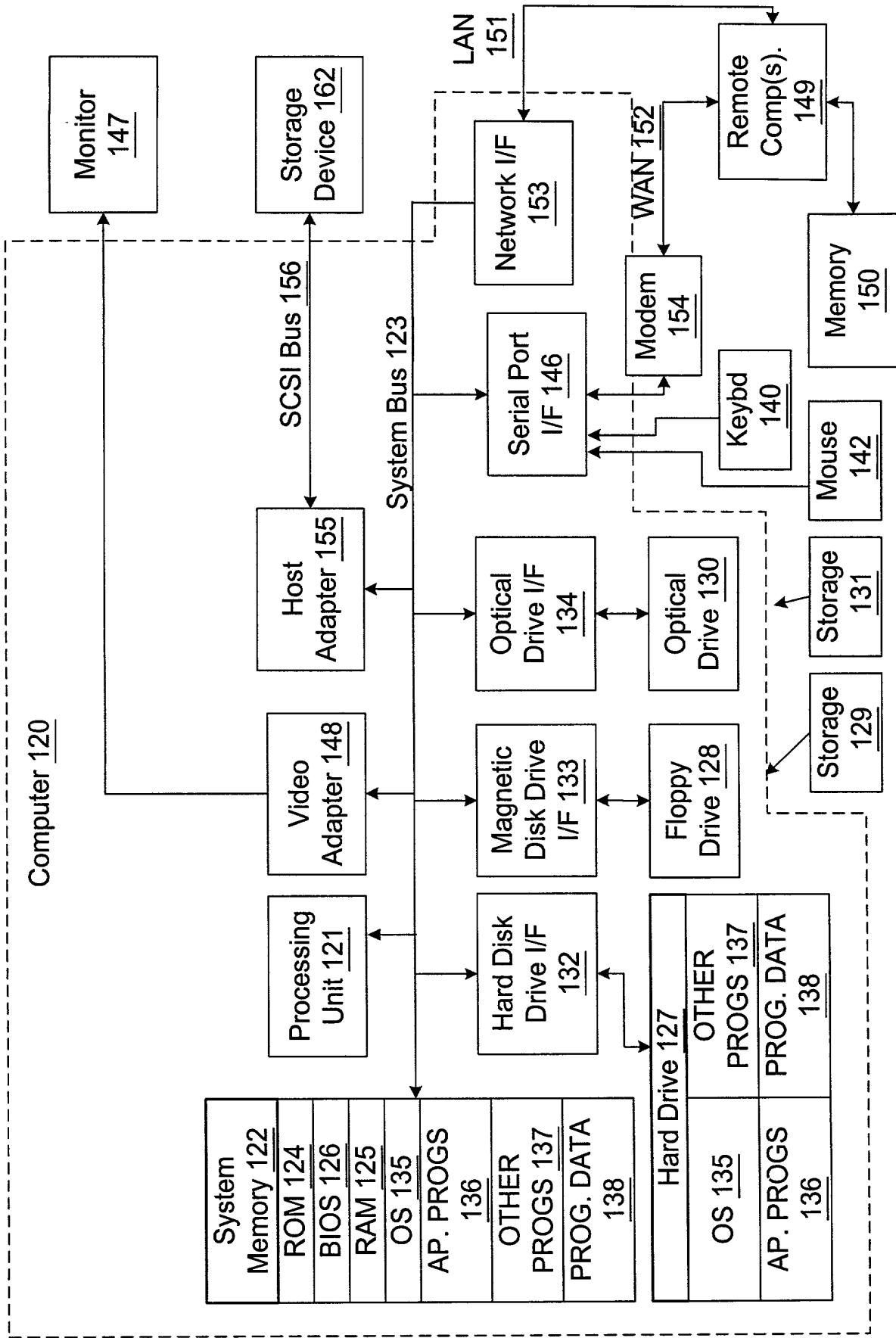

Fig. 10





**Fig. 12**

00860" 41972960

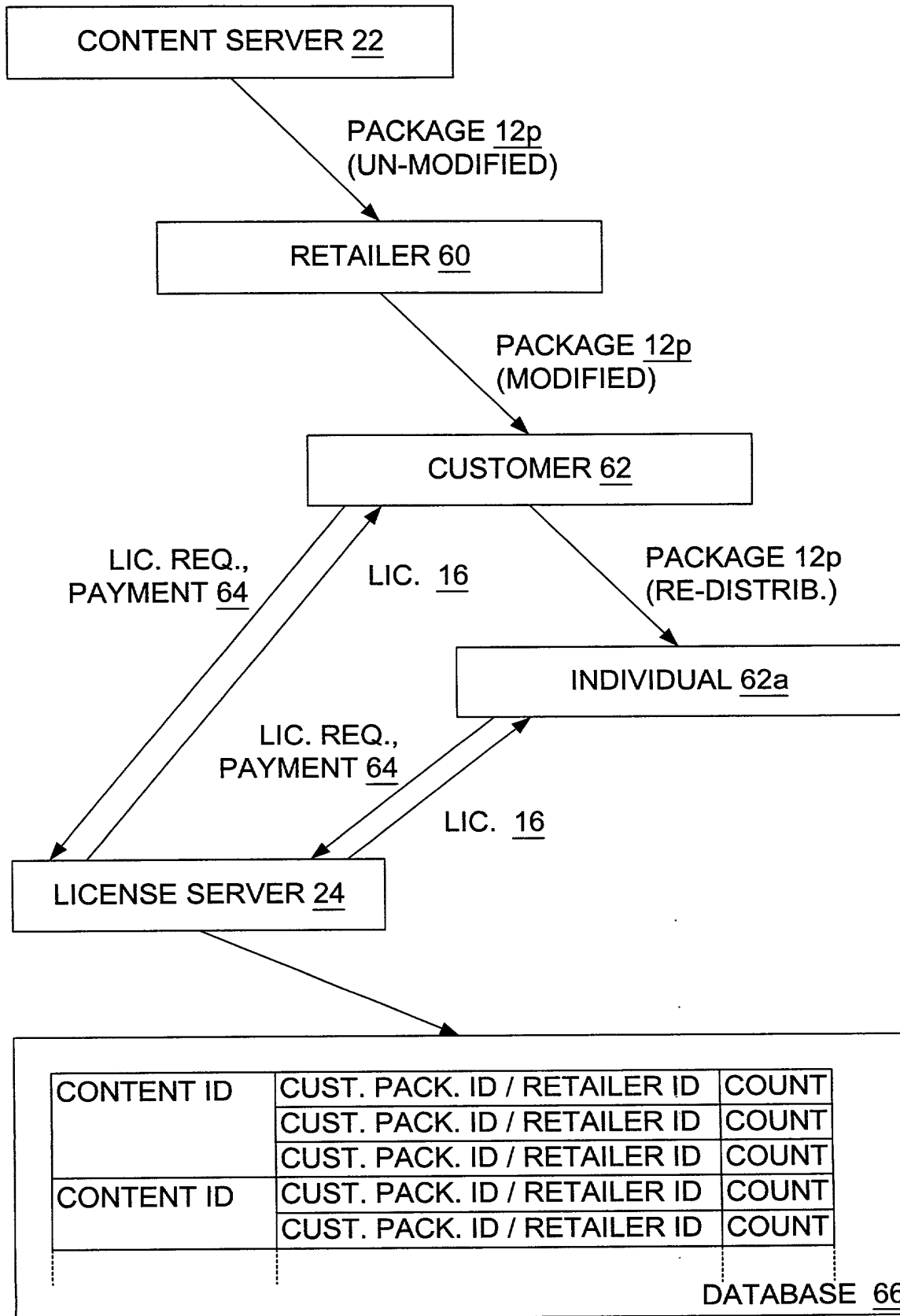

Fig. 13

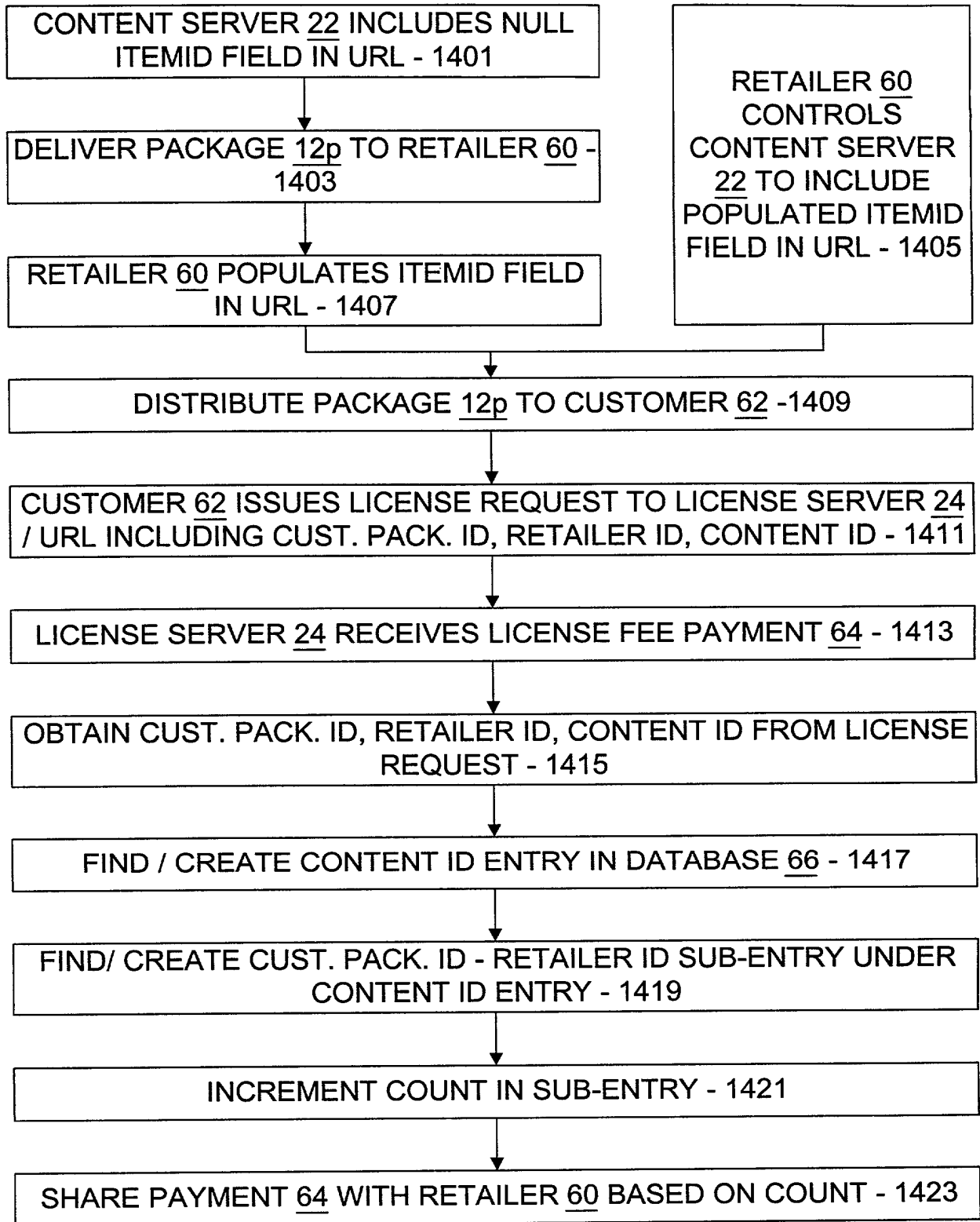

Fig. 14

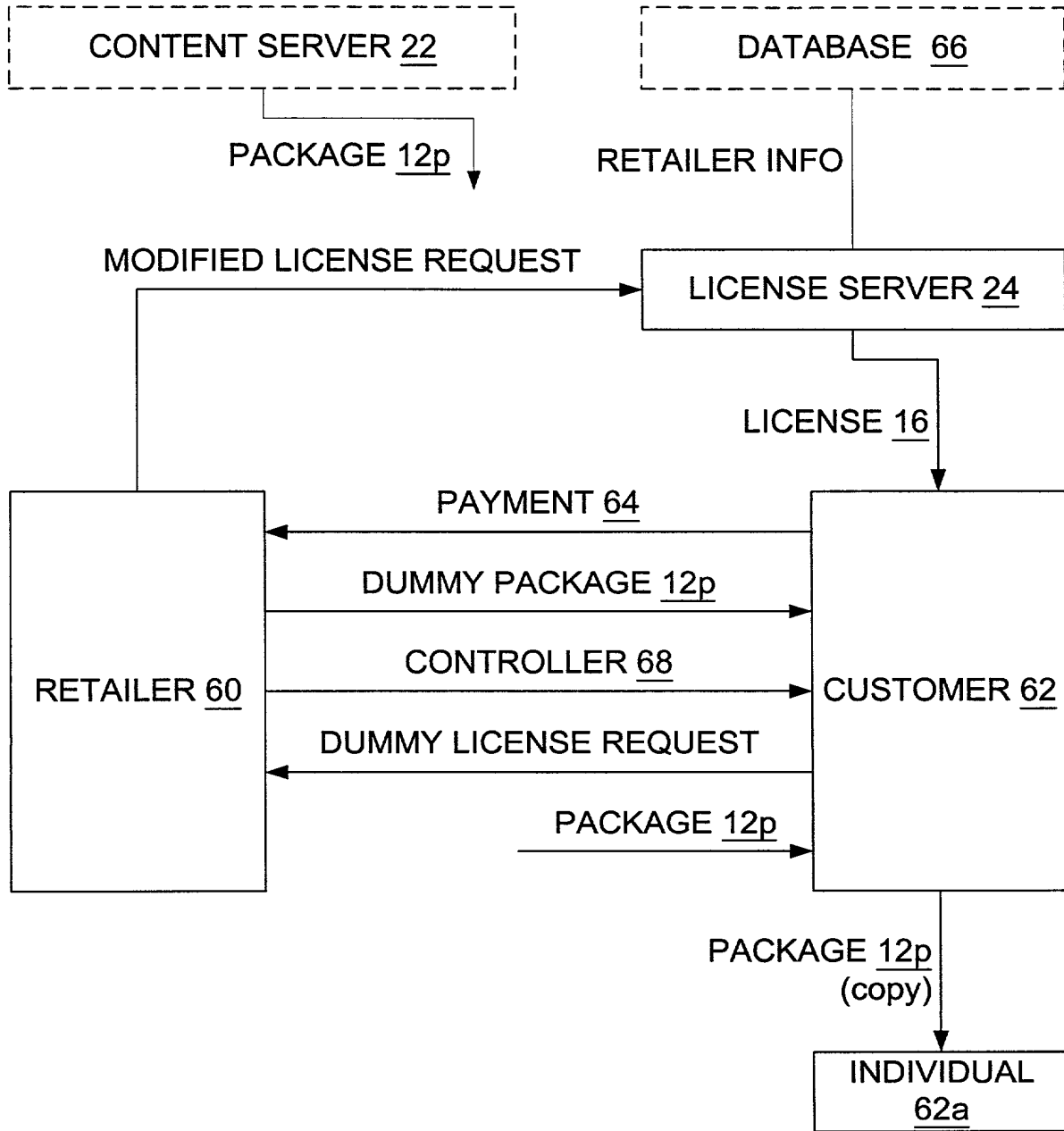

Fig. 15

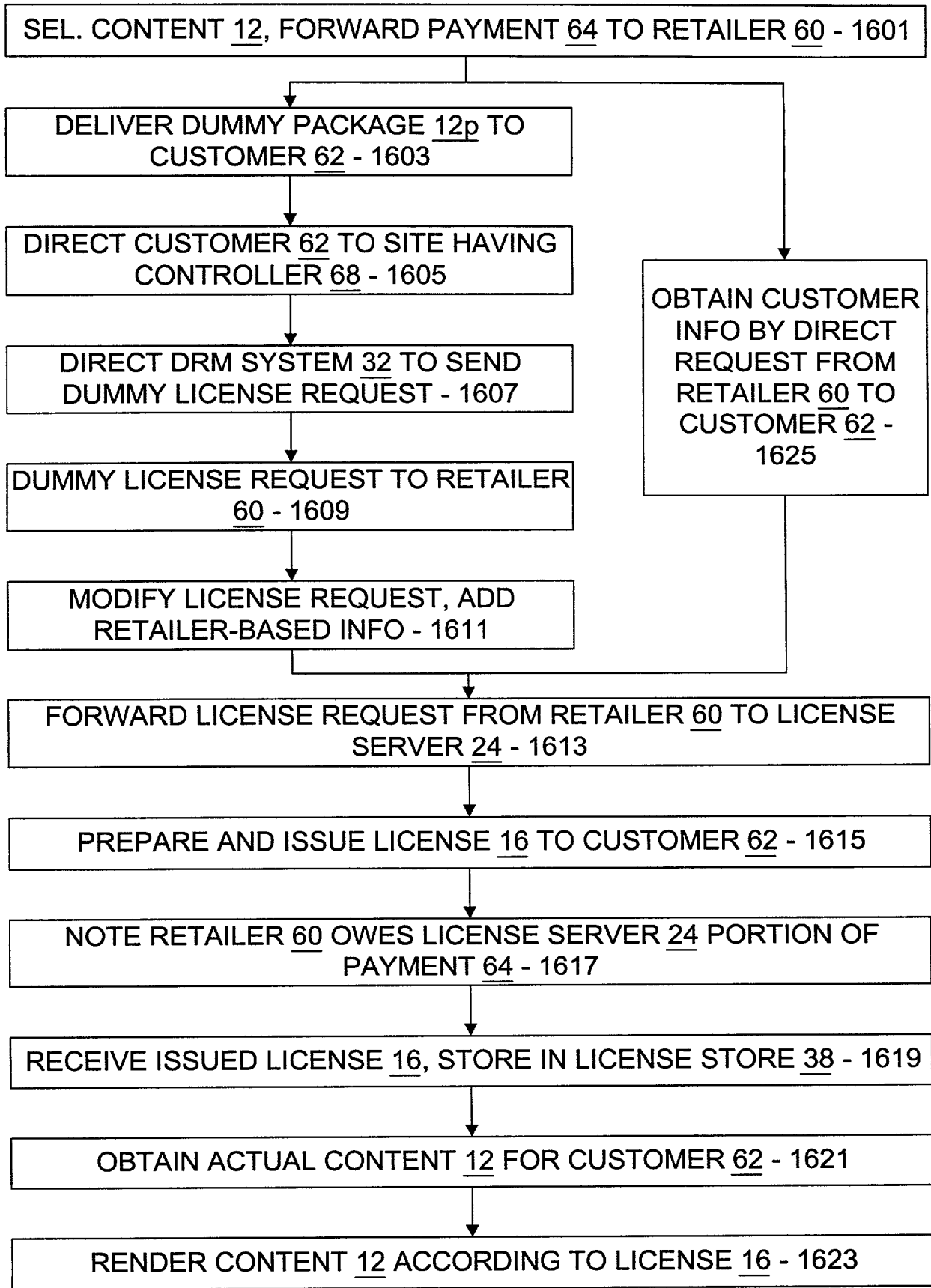

Fig. 16



IN THE UNITED STATES PATENT AND TRADEMARK OFFICE

In Re Application of: EL531429456US

Rajasekhar Abburi Group Art Unit: Not Yet Assigned

Examiner: Not Yet Assigned

For: Retail Transactions Involving Distributed and Super-Distributed Digital Content in a Digital Rights Management (DRM) System

DECLARATION AND POWER OF ATTORNEY

As a below named inventor, I hereby declare that:

My residence, post office address and citizenship are as stated below next to my name; and

I believe that I am the original, first and sole inventor (if only one name is listed below) or an original, first and joint inventor (if plural names are listed below) of the subject matter which is claimed and for which a

- [x] Utility Patent [ ] Design Patent

is sought on the invention, whose title appears above, the specification of which:

- [x] is attached hereto. [ ] was filed on \_\_\_\_\_ as Serial No. \_\_\_\_\_. [ ] said application having been amended on \_\_\_\_\_.

I hereby state that I have reviewed and understand the contents of the above-identified specification, including the claims, as amended by any amendment referred to above.

I acknowledge the duty to disclose to the U.S. Patent and Trademark Office all information known to be material to the patentability of this application in accordance with 37 C.F.R. §1.56.

I hereby claim foreign priority benefits under 35 U.S.C. §119(a-d) of any foreign application(s) for patent or inventor's certificate listed below and have also identified below any foreign application for patent or inventor's certificate having a filing date before that of any application on which priority is claimed.

COBECO PATENT

Priority Claimed (If X'd)	Country	Serial Number	Date Filed
_____	_____	_____	_____
_____	_____	_____	_____
_____	_____	_____	_____
_____	_____	_____	_____

I hereby claim the benefit under 35 U.S.C. §120 of any **United States application(s)** listed below and, insofar as the subject matter of each of the claims of this application is not disclosed in the prior United States application in the manner provided by the first paragraph of 35 U.S.C. §112, I acknowledge the duty to disclose to the U.S. Patent and Trademark Office all information known to be material to patentability as defined in 37 C.F.R. §1.56 which became available between the filing date of the prior application and the national or PCT international filing date of this application.

Serial Number	Date Filed	Patented/Pending/Abandoned
_____	_____	_____
_____	_____	_____
_____	_____	_____
_____	_____	_____

I hereby claim the benefit under 35 U.S.C. §119(e) of any United States **provisional application(s)** listed below:

Serial Number	Date Filed
_____	_____
_____	_____

00000000000000000000000000000000

I hereby appoint the following persons as attorney(s) and/or agent(s) to prosecute this application and to transact all business in the Patent and Trademark Office connected therewith:

**Katie E. Sako                      Registration No. 32,628**

**Daniel D. Crouse                Registration No. 32,022**

of **MICROSOFT CORPORATION**, One Microsoft Way, Redmond, WA 98052 and

**Steven J. Rocci                 Registration No. 30,489**

**Steven H. Meyer                Registration No. 37,189**

of **WOODCOCK WASHBURN KURTZ MACKIEWICZ & NORRIS LLP**, One Liberty Place – 46<sup>th</sup> Floor, Philadelphia, Pennsylvania 19103.

Please address all telephone calls and correspondence to:

Steven H. Meyer  
**WOODCOCK WASHBURN KURTZ  
MACKIEWICZ & NORRIS LLP**  
One Liberty Place – 46<sup>th</sup> Floor  
Philadelphia, PA 19103  
Telephone: (215) 568-3100

I hereby declare that all statements made herein of my own knowledge are true and that all statements made on information and belief are believed to be true; and further that these statements were made with the knowledge that willful false statements and the like so made are punishable by fine or imprisonment, or both, under Section 1001 of Title 18 of the United States Code and that such willful false statements may jeopardize the validity of the application or any patent issued thereon.

WOODCOCK WASHBURN KURTZ MACKIEWICZ & NORRIS LLP

<b>Name:</b> Rajasekhar Abburi	<b>Signature:</b> _____  <b>Date of Signature:</b> _____  <b>Citizenship:</b> India
<b>Mailing Address:</b> 7844 NE 10 <sup>th</sup> Street Medina, Washington 98039	
<b>City/State of Actual Residence</b> Medina, Washington	

<b>Name:</b>	<b>Signature:</b> _____  <b>Date of Signature:</b> _____  <b>Citizenship:</b> _____
<b>Mailing Address:</b>	
<b>City/State of Actual Residence</b>	

<b>Name:</b>	<b>Signature:</b> _____  <b>Date of Signature:</b> _____  <b>Citizenship:</b> _____
<b>Mailing Address:</b>	
<b>City/State of Actual Residence</b>	

003260-ETHS72560